

# HYDRAULIC BALL VALVES



866-FLANGES | 513.527.4444 | Fax 513.527.4449  
sales@anchorfluidpower.com | anchorfluidpower.com

<b>AE2 / Two-Way Block Body Threaded</b>	<b>16</b>
<b>AB2 / Two-Way Round Body Threaded</b>	<b>18</b>
<b>AV2 / Two-Way Excavator Style</b>	<b>20</b>
<b>AV3 / Three-Way Excavator Style</b>	<b>22</b>
<b>AE3 / Three-Way Block Body Threaded</b>	<b>24</b>
<b>AE3K / “True” Three-Way Block Body Threaded</b>	<b>26</b>
<b>AB3 / Three-Way Body Threaded</b>	<b>28</b>
<b>AES / Two-Way Block Body Flange Head</b>	<b>30</b>
<b>ABS / Two-Way Round Body Flange Head</b>	<b>32</b>
<b>AEF / Two-Way Block Body Flat Faced</b>	<b>34</b>
<b>ABF / Two-Way Round Body Flat Faced</b>	<b>36</b>
<b>AES/F &amp; ABS/F / Two-Way Flange Head X Flat Face</b>	<b>38</b>
<b>APK / Two-Way Manifold Mount</b>	<b>40</b>
<b>Locking Kits</b>	<b>42</b>
<b>Handles</b>	<b>43</b>
<b>LV2B / 1000 WOG Two-Way Stainless Steel</b>	<b>44</b>
<b>MV2B / 2000 WOG Two-Way Stainless Steel</b>	<b>45</b>

**BALL VALVE PRESSURE SPECIFICATIONS**

Anchor Fluid Power ball valves are tested in accordance with API 598-B16.34-API602 standards. End connections are manufactured in accordance with one or more of the following specifications.

**SAE J1926-1**

**SAE J518-1**

**ISO 6162-1**

**SAE J514**

**SAE J1453-1**

**SAE J518-2**

**ISO 6162-2**

**ANSI B.1.20.1**

# AE2 Series - Two-Way Block Body Threaded

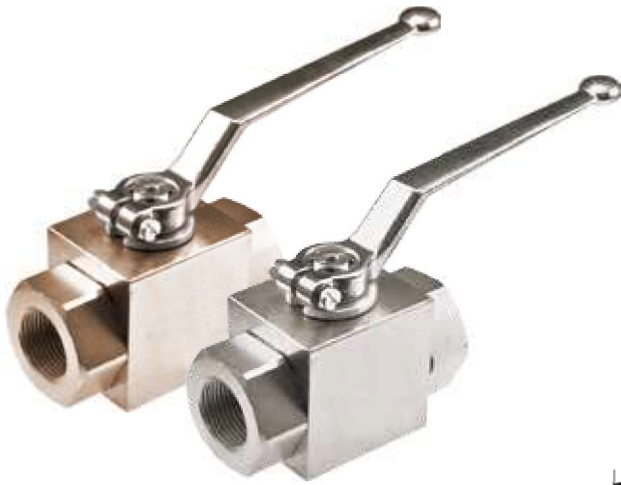

- Carbon Steel with Zinc Chromate Plating (RoHS Compliant)
- 316 stainless steel available from stock
- Unrestricted bore up to 1" size
- POM seats & Buna O-rings standard on carbon steel valves
- Optional seal materials available for extreme temperature applications & fluid compatibility (Consult Factory)

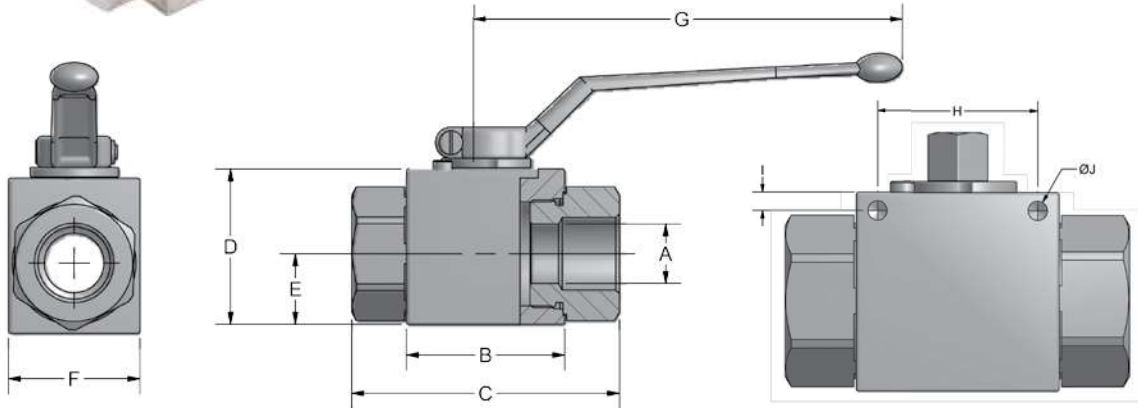

Standard handles supplied are:  
Refer to page 43 for details.

1/8" - 1/2"  
3/4" - 1 1/2"

C1010ZB  
C1200ZB

Optional Mounting Holes

AE2 SERIES FULL BORE															
SERIES		PSI MAX	A BORE	B	C	D		E	F		G	H	I	J	WEIGHT
NPT	SAE					CARBON	STAINLESS		CARBON	STAINLESS					
AE2 N1/8	N/A	7250	.16	1.67	2.80	1.38	C/F	.57	1.18	C/F	4.33	C/F	C/F	C/F	1.1 LBS
AE2 N1/4	AE2 S#4	7250	.24	1.67	2.80	1.38	1.38	.57	1.18	1.38	4.33	1.34	.18	.21	1.1 LBS
AE2 N3/8	AE2 S#6	7250	.39	1.75	2.87	1.57	1.57	.69	1.38	1.57	4.33	1.34	.18	.21	1.4 LBS
AE2 N1/2	AE2 S#8	7250	.51	1.90	3.27	1.69	1.77	.71	1.46	1.77	4.33	1.42	.20	.21	1.7 LBS
AE2 N3/4	AE2 S#12	5800	.79	2.46	3.74	2.17	2.17	.92	1.77	2.17	7.09	1.97	.24	.25	3.3 LBS
AE2 N1	AE2 S#16	5075	.98	2.62	4.41	2.56	2.56	1.16	2.17	2.56	7.09	1.97	.24	.25	5.0 LBS

AE2 SERIES REDUCED BORE															
SERIES		PSI MAX	A BORE	B	C	D		E	F		G	H	I	J	WEIGHT
NPT	SAE					CARBON	STAINLESS		CARBON	STAINLESS					
AE2 N1-1/4R	AE2 S#20R	5075	.98	2.62	4.72	2.56	2.56	1.16	2.17	2.56	7.09	C/F	C/F	C/F	5.2 LBS
AE2 N1-1/2R	AE2 S#24R	5075	.98	2.62	4.88	2.56	2.56	1.16	2.17	2.56	7.09	C/F	C/F	C/F	5.5 LBS



# AE2 Series - Two-Way Block Body Threaded

## Model Code Breakdown

AE2 N1/2 \_ - 1 1 D B \_ \_ \_

**VALVE SERIES**

**CONNECTION TYPE/SIZE**

N	NPT Pipe Thread
S	SAE Straight Thread
B	BSPP Thread

**BORE RESTRICTION**

blank	Unrestricted Bore
R	Restricted Bore

**BODY & ADAPTER MATERIAL**

1	Carbon Steel
2	316 Stainless Steel

**BALL & STEM MATERIAL**

1	Carbon Steel
2	316 Stainless Steel

**OPTIONAL MOUNTING HOLE**

MH	Mounting Holes
----	----------------

**LOCKING KIT OR  
OPTIONAL HANDLE CODE**  
(See pages 42 & 43)

**ADAPTER & STEM SEALS**

B	Buna- Standard
V	Viton (Std on S/S)

**BALL & STEM SEATS**

D	POM- Standard
P	PEEK

Please consult your system's seal manufacturer for recommendation of seal selection, as Anchor Fluid Power does not accept responsibility for seal selection.

**MAXIMUM & MINIMUM WORKING TEMPERATURES FOR SEAL MATERIALS**

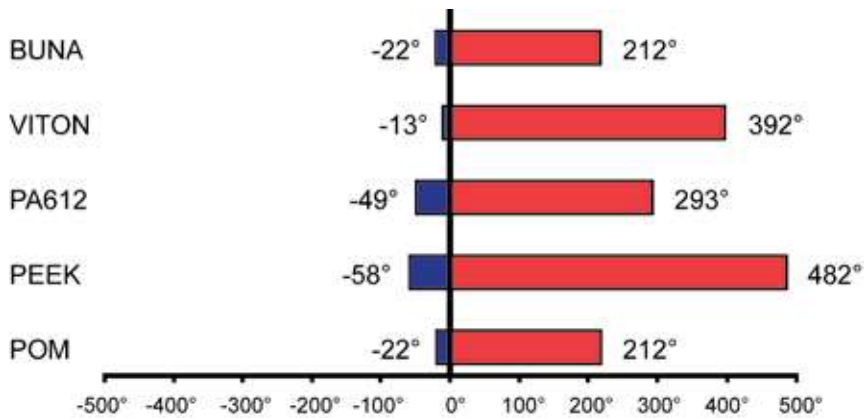

# AB2 Series - Two-Way Round Body Threaded



- Carbon Steel with Zinc Chromate Plating (RoHS Compliant)
- 316 stainless steel available from stock
- Unrestricted bore available through 2" size
- POM seats & Buna O-rings standard on carbon steel valves
- Optional seal materials available for extreme temperature applications & fluid compatibility (Consult Factory)

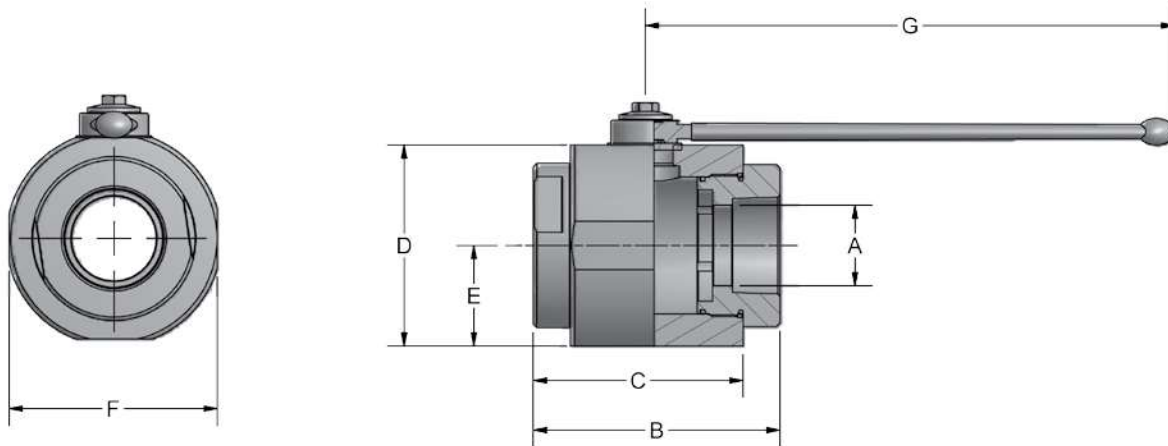

Standard handle supplied is C81302B. Refer to page 43 for details.

AB2 SERIES FULL BORE										
NPT	SAE	PSI MAX	A BORE	B	C	D	E	F	G	WEIGHT
AB2 N1-1/4	AB2 S#20	5075	1.26	4.53	3.74	3.66	1.83	3.46	11.81	15.4 LBS
AB2 N1-1/2	AB2 S#24	5075	1.57	5.16	4.25	4.21	2.11	4.02	11.81	16.3 LBS
AB2 N2	AB2 S#32	5075	1.97	5.51	4.53	4.49	2.24	4.65	11.81	19.9 LBS

NPT threads in accordance with ANSI B.1.20.1 specifications.  
SAE threads in accordance with SAE J1926-1 specifications.



# AB2 Series - Two-Way Round Body Threaded

## Model Code Breakdown

AB2 N1 1/2 \_ - 1 1 D B \_

**VALVE SERIES**

**CONNECTION TYPE/SIZE**

N	NPT Pipe Thread
S	SAE Straight Thread
B	BSPP Thread

**BORE RESTRICTION**

blank	Unrestricted Bore
R	Restricted Bore

**BODY & ADAPTER MATERIAL**

1	Carbon Steel
2	316 Stainless Steel

**BALL & STEM MATERIAL**

1	Carbon Steel
2	316 Stainless Steel

**LOCKING KIT OR  
OPTIONAL HANDLE CODE**  
(See pages 42 & 43)

**ADAPTER & STEM SEALS**

B	Buna- Standard
V	Viton (Std on S/S)

**BALL & STEM SEATS**

D	POM- Standard
P	PEEK

Please consult your system's seal manufacturer for recommendation of seal selection, as Anchor Fluid Power does not accept responsibility for seal selection.

**MAXIMUM & MINIMUM WORKING TEMPERATURES FOR SEAL MATERIALS**

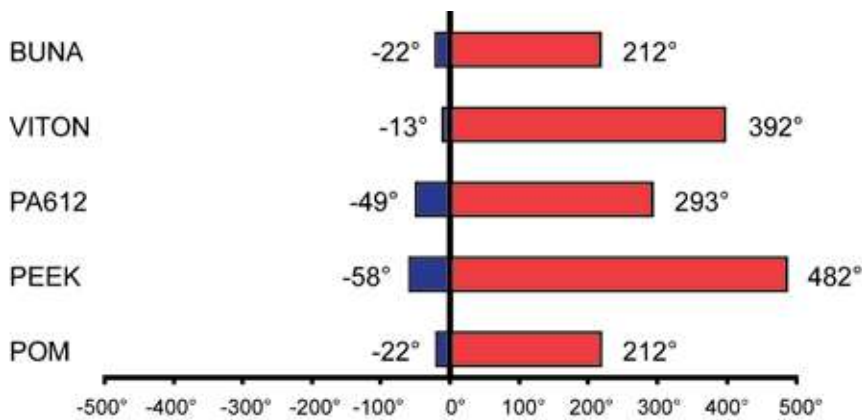

All temperatures are in degrees Fahrenheit.

# AV2 Series - Two-Way Excavator Style



- Carbon Steel with Zinc Chromate Plating (RoHS Compliant)
- Hex stem eliminates need for attached handle
- Detented stop washer prevents accidental actuation
- Mounting holes standard
- Max pressure of 7250 PSI on all sizes
- No handle available for this series
- Optional weld mounting plates sold separately

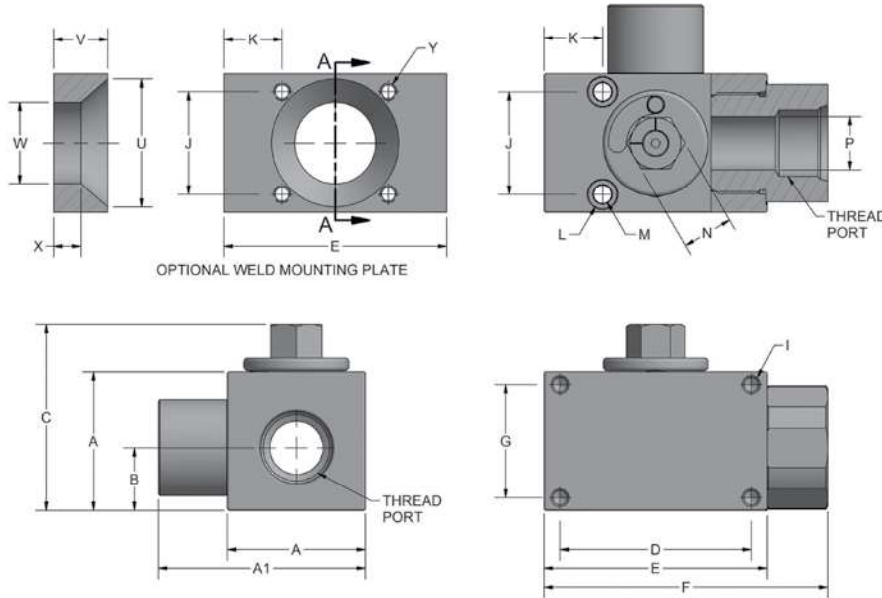

\*Weld Plate Mounting Pattern Matches "J" Dimension (Top of Valve)

AV2 SERIES																
NPT	SAE	A	B	C	D	E	F	G	I	J	K	L	M	N	P	WEIGHT
AV2N1/2	AV2S#8	1.77	0.79	2.46	2.52	3.15	4.07	1.30	M8 X 1.25	1.26	0.91	0.41	0.25	0.75	0.51	2.9 LBS
AV2N3/4	AV2S#12	2.17	0.92	3.05	3.15	3.98	5.10	1.69	M8 X 1.25	1.57	1.00	0.53	0.32	0.94	0.79	5.3 LBS
AV2N1	AV2S#16	2.56	1.16	3.44	3.54	4.13	5.26	2.09	M8 X 1.25	1.89	1.08	0.53	0.32	0.94	0.98	7.6 LBS
AV2N1-1/4R	AV2S#20R	2.56	1.16	3.44	3.54	4.13	5.26	2.09	M8 X 1.25	1.89	1.08	0.53	0.32	0.94	0.98	7.2 LBS
AV2N1-1/4	AV2S#20	3.15	1.32	4.07	3.39	4.13	5.26	2.52	M8 X 1.25	2.36	0.96	0.53	0.32	1.26	1.26	11.0 LBS

WELD MOUNTING PLATES							
PART #	VALVE SIZE	U	V	W	X	Y	KIT INCLUDED SHCS
*WP-AV#8U	1/2"	N/A	1.00	N/A	N/A	M6 X 1.00	M6 X 50 MM
WP-AV#12U	3/4"	1.97	1.00	1.50	.50	5/16-18 UNC-2B	5/16 X 2.25"
WP-AV#16U	1" & 1 1/4" REDUCED	2.36	1.00	1.50	.50	5/16-18 UNC-2B	5/16 X 2.75"
WP-AV#20U	1 1/4" FULL	2.86	1.00	1.50	.50	5/16-18 UNC-2B	5/16 X 3.25"

\*No internal weld hole on this size weld plate



# AV2 Series - Two-Way Block Body Threaded

## Model Code Breakdown

AV2 N1/2 \_ - 1 1 D V

**VALVE SERIES**

**CONNECTION TYPE/SIZE**

N	NPT Pipe Thread
S	SAE Straight Thread

**BORE RESTRICTION**

blank	Unrestricted Bore
R	Restricted Bore

**BODY & ADAPTER MATERIAL**

1	Carbon Steel
---	--------------

**ADAPTER & STEM SEALS**

V	Viton (Standard)
---	------------------

**BALL & STEM SEATS**

D	POM
---	-----

**BALL & STEM MATERIAL**

1	Carbon Steel
---	--------------

Please consult your system's seal manufacturer for recommendation of seal selection, as Anchor Fluid Power does not accept responsibility for seal selection.

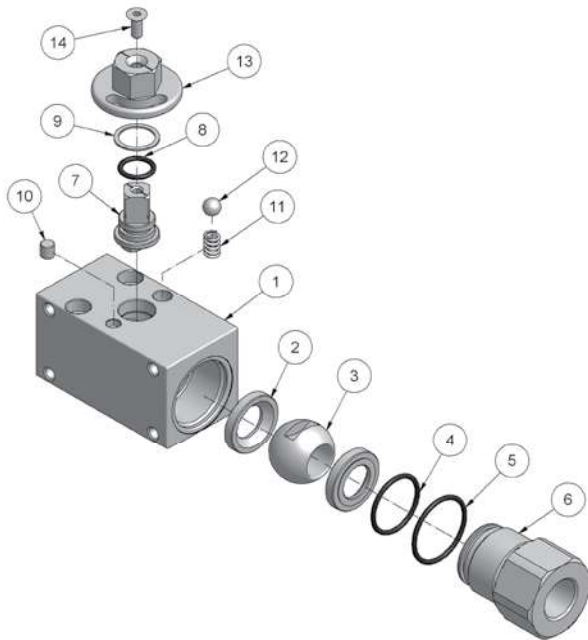

Parts List		
ITEM	QTY	PART NUMBER
1	1	AV2 Valve Body
2	2	Ball Seats
3	1	Ball
4	1	Adapter O-Ring (Small)
5	1	Adapter O-Ring (Large)
6	1	Adapter
7	1	Stem
8	1	Stem O-Ring
9	1	Stem Seat
10	1	Stop Pin
11	1	Spring
12	1	Detent Ball
13	1	Alignment Stop
14	1	Screw



# AV3 Series - Three-Way Excavator Style



- Carbon Steel with Zinc Chromate Plating (RoHS Compliant)
- Hex stem eliminates need for attached handle
- No handle available for this series
- Detented stop washer prevents accidental actuation
- Mounting holes standard
- Max pressure of 5075 PSI on all sizes
- Optional weld mounting plates sold separately

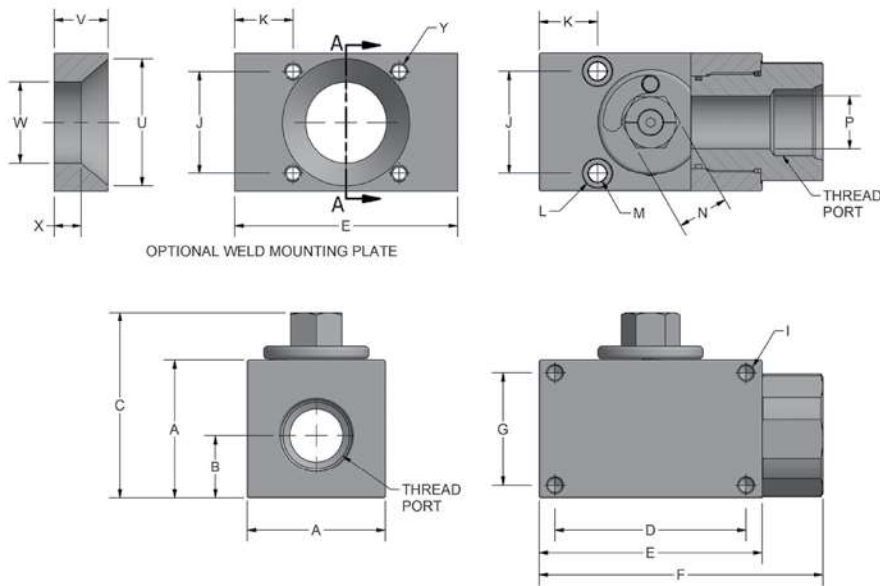

\*Weld Plate Mounting Pattern Matches "J" Dimension (Top of Valve)

AV3 SERIES																		
NPT	SAE	A	A1	B	C	D	E	F	G	H	I	J	K	L	M	N	P	WEIGHT
AV3LN1/2	AV3LS#8	1.77	2.62	0.79	2.74	2.52	3.15	4.07	1.30	2.46	M8 X 1.25	1.26	0.91	0.41	0.25	0.75	0.51	3.0 LBS
AV3LN3/4	AV3LS#12	2.17	3.35	0.92	2.89	3.15	3.98	5.10	1.69	3.05	M8 X 1.25	1.57	1.00	0.53	0.32	0.94	0.79	5.5 LBS
AV3LN1	AV3LS#16	2.56	3.84	1.16	3.29	3.54	4.13	5.26	2.09	3.44	M8 X 1.25	1.89	1.08	0.53	0.32	0.94	0.98	7.9 LBS
AV3LN1-1/4R	AV3LS#20R	2.56	3.90	1.16	3.29	3.54	4.13	5.26	2.09	3.44	M8 X 1.25	1.89	1.08	0.53	0.32	0.94	0.98	7.7 LBS
AV3LN1-1/4	AV3LS#20	3.15	4.65	1.32	3.88	3.39	4.13	5.26	2.52	4.07	M8 X 1.25	2.36	0.96	0.53	0.32	1.26	1.26	11.7 LBS

WELD MOUNTING PLATES							
PART #	VALVE SIZE	U	V	W	X	Y	KIT INCLUDED SHCS
*WP-AV#8U	1/2"	N/A	1.00	N/A	N/A	M6 X 1.00	M6 X 50 MM
WP-AV#12U	3/4"	1.97	1.00	1.50	.50	5/16-18 UNC-2B	5/16 X 2.25"
WP-AV#16U	1" & 1 1/4" REDUCED	2.36	1.00	1.50	.50	5/16-18 UNC-2B	5/16 X 2.75"
WP-AV#20U	1 1/4" FULL	2.86	1.00	1.50	.50	5/16-18 UNC-2B	5/16 X 3.25"



# AV3 Series - Three-Way Excavator Style

## Model Code Breakdown

AV3L N1/2 - 1 1 D V

**VALVE SERIES**

**CONNECTION TYPE/SIZE**

N	NPT Pipe Thread
S	SAE Straight Thread

**BORE RESTRICTION**

blank	Unrestricted Bore
R	Restricted Bore

**BODY & ADAPTER MATERIAL**

1	Carbon Steel
---	--------------

**ADAPTER & STEM SEALS**

V	Viton (Standard)
---	------------------

**BALL & STEM SEATS**

D	POM
---	-----

**BALL & STEM MATERIAL**

1	Carbon Steel
---	--------------

Please consult your system's seal manufacturer for recommendation of seal selection, as Anchor Fluid Power does not accept responsibility for seal selection.

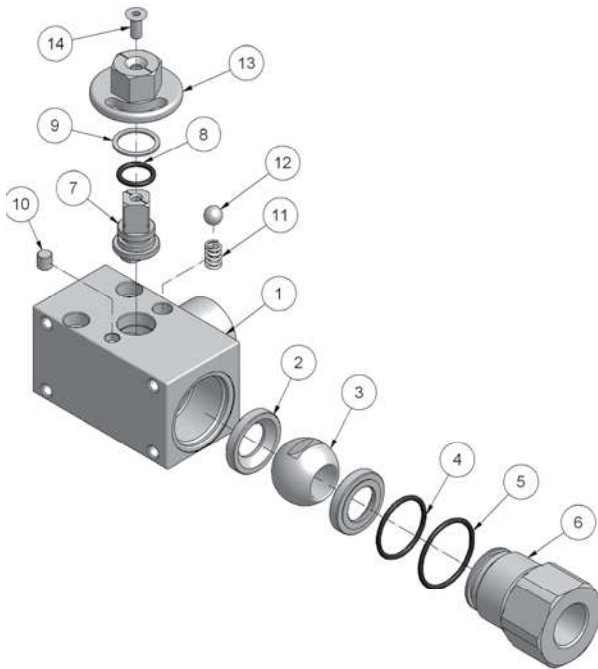

Parts List		
ITEM	QTY	PART NUMBER
1	1	AV3 Valve Body
2	2	Ball Seats
3	1	Ball
4	1	Adapter O-Ring (Small)
5	1	Adapter O-Ring (Large)
6	1	Adapter
7	1	Stem
8	1	Stem O-Ring
9	1	Stem Seat
10	1	Stop Pin
11	1	Spring
12	1	Detent Ball
13	1	Alignment Stop
14	1	Screw

# AE3 Series - Three-Way Block Body Threaded



- Carbon Steel with Zinc Chromate Plating (RoHS Compliant)
- 316 stainless steel available from stock
- POM seats & Buna O-rings standard on carbon steel valves
- Optional seal materials available for extreme temperature applications & fluid compatibility (Consult Factory)

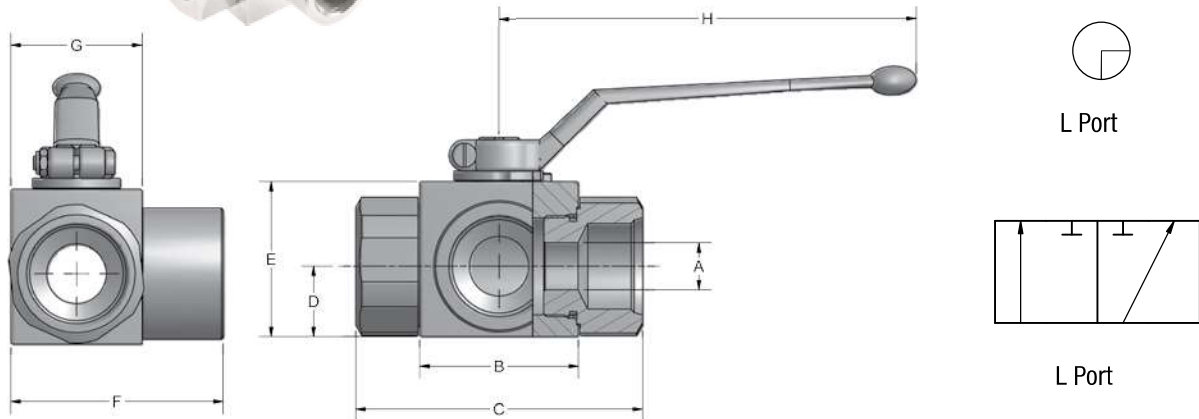

Standard handles supplied are: 1/8" - 1/2" C1010ZB  
 Refer to page 43 for details. 3/4" - 1 1/2" C1200ZB

AE3 SERIES FULL BORE											
NPT	SAE	PSI MAX	A BORE	B	C	D	E	F	G	H	WEIGHT
AE3 L N1/8	N/A	7250	.16	1.70	2.80	.57	1.38	1.91	1.18	4.33	1.2 LBS
AE3 L N1/4	AE3 L S#4	7250	.24	1.70	2.80	.57	1.38	1.91	1.18	4.33	1.2 LBS
AE3 L N3/8	AE3 L S#6	7250	.39	1.75	2.87	.67	1.57	2.15	1.38	4.33	1.5 LBS
AE3 L N1/2	AE3 L S#8	7250	.51	1.91	3.27	.71	1.69	2.30	1.46	4.33	1.8 LBS
AE3 L N3/4	AE3 L S#12	5075	.79	2.46	3.74	.92	2.17	2.95	1.77	7.09	3.5 LBS
AE3 L N1	AE3 L S#16	5075	.98	2.62	4.41	1.16	2.56	3.44	2.17	7.09	5.3 LBS

AE3 SERIES REDUCED BORE											
NPT	SAE	PSI MAX	A BORE	B	C	D	E	F	G	H	WEIGHT
AE3 L N1-1/4R	AE3 L S#20R	5075	.98	2.62	4.72	1.16	2.56	3.44	2.17	7.09	5.7 LBS
AE3 L N1-1/2R	AE3 L S#24R	5075	.98	2.62	4.88	1.16	2.56	3.44	2.17	7.09	6.1 LBS

Only pressurize center port. Side ports should not be pressurized or be exposed to back pressure that is greater than the inlet pressure. Failure to follow these guidelines will result in internal leakage through the valve. For applications requiring pressure applied to side ports, please refer to AE3K Series valves on page 26.

NPT threads in accordance with ANSI B.1.20.1 specifications.  
 SAE threads in accordance with SAE J1926-1 specifications.



# AE3 Series - Three-Way Block Body Threaded

## Model Code Breakdown

AE3L N1/2 \_ - 1 1 D B \_

**VALVE SERIES**

**PORT TYPE**

L	"Diverter" L-Port
---	-------------------

**CONNECTION TYPE/SIZE**

N	NPT Pipe Thread
S	SAE Straight Thread

**BORE RESTRICTION**

blank	Unrestricted Bore
R	Restricted Bore

**BODY & ADAPTER MATERIAL**

1	Carbon Steel
2	316 Stainless Steel

**BALL & STEM MATERIAL**

1	Carbon Steel
2	316 Stainless Steel

**LOCKING KIT OR  
OPTIONAL HANDLE CODE**  
(See pages 42 & 43)

**ADAPTER & STEM SEALS**

B	Buna- Standard
V	Viton (Std on S/S)

**BALL & STEM SEATS**

D	POM- Standard
P	PEEK

Please consult your system's seal manufacturer for recommendation of seal selection, as Anchor Fluid Power does not accept responsibility for seal selection.

**MAXIMUM & MINIMUM WORKING TEMPERATURES FOR SEAL MATERIALS**

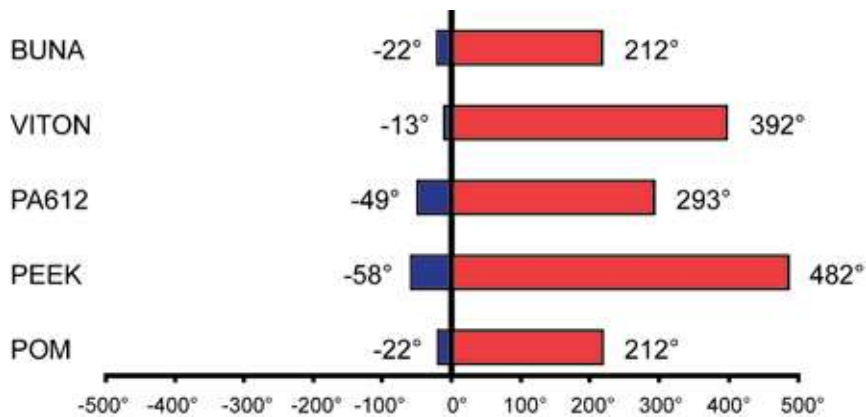

All temperatures are in degrees Fahrenheit.

# HYDRAULIC BALL VALVES

## AE3K Series - Three-Way Block Body Threaded



- Any port may be pressurized on this series valve ("True" 3-way valve)
- Carbon Steel with Zinc Chromate Plating (RoHS Compliant)
- POM seats & Buna O-rings standard on carbon steel valves
- Optional seal materials available for extreme temperature applications & fluid compatibility (Consult Factory)

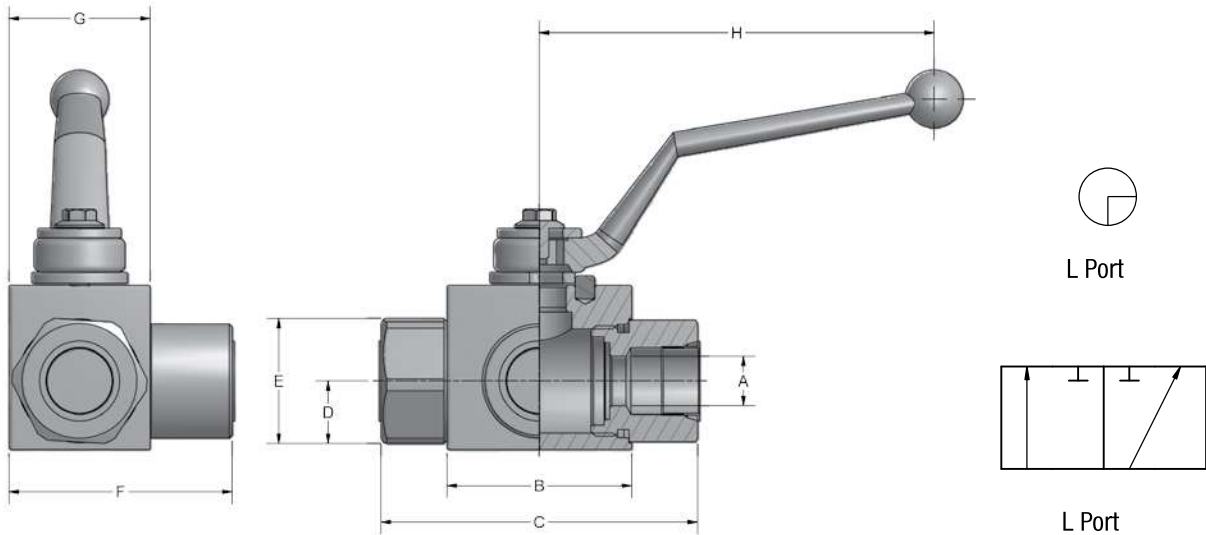

Standard handles supplied are: 1/4" - 1/2" C1010ZB  
 Refer to page 43 for details. 3/4" - 1" C1200ZB

AE3K SERIES FULL BORE											
NPT	SAE	PSI MAX	A BORE	B	C	D	E	F	G	H	WEIGHT
AE3K L N1/4	AE3K L S#4	7250	.24	1.67	2.80	.57	1.38	1.91	1.18	4.33	1.2 LBS
AE3K L N3/8	AE3K L S#6	7250	.39	1.75	2.87	.69	1.57	2.15	1.38	4.33	1.5 LBS
AE3K L N1/2	AE3K L S#8	7250	.51	1.91	3.27	.71	1.69	2.30	1.46	4.33	1.8 LBS
AE3K L N3/4	AE3K L S#12	5075	.79	2.46	3.74	.92	2.17	2.95	1.77	7.01	3.5 LBS
AE3K L N1	AE3K L S#16	5075	.98	2.62	4.41	1.16	2.56	3.44	2.17	7.01	5.3 LBS

NPT threads in accordance with ANSI B.1.20.1 specifications.  
 SAE threads in accordance with SAE J1926-1 specifications.



866-FLANGES | 513.527.4444 | Fax 513.527.4449  
 sales@anchorfluidpower.com | anchorfluidpower.com

# AE3K Series - Three-Way Block Body Threaded

## Model Code Breakdown

AE3KL N1/2 \_ - 1 1 D B \_

**VALVE SERIES**

**PORT TYPE**

L	"Diverter" L-Port
---	-------------------

**CONNECTION TYPE/SIZE**

N	NPT Pipe Thread
S	SAE Straight Thread

**BORE RESTRICTION**

blank	Unrestricted Bore
R	Restricted Bore

**BODY & ADAPTER MATERIAL**

1	Carbon Steel
---	--------------

**BALL & STEM MATERIAL**

1	Carbon Steel
---	--------------

**LOCKING KIT OR  
OPTIONAL HANDLE CODE**  
(See pages 42 & 43)

**ADAPTER & STEM SEALS**

B	Buna- Standard
V	Viton

**BALL & STEM SEATS**

D	POM- Standard
---	---------------

Please consult your system's seal manufacturer for recommendation of seal selection, as Anchor Fluid Power does not accept responsibility for seal selection.

**MAXIMUM & MINIMUM WORKING TEMPERATURES FOR SEAL MATERIALS**

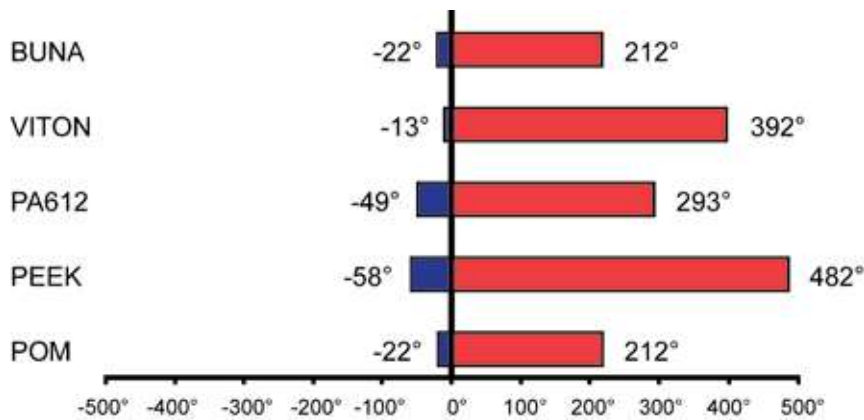

All temperatures are in degrees Fahrenheit.

# AB3 Series - Three-Way Threaded



- Carbon Steel with Zinc Chromate Plating (RoHS Compliant)
- POM seats & Buna O-rings standard on carbon steel valves
- Optional seal materials available for extreme temperature applications & fluid compatibility (Consult Factory)



L Port

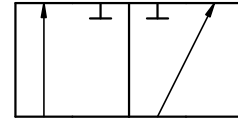

L Port

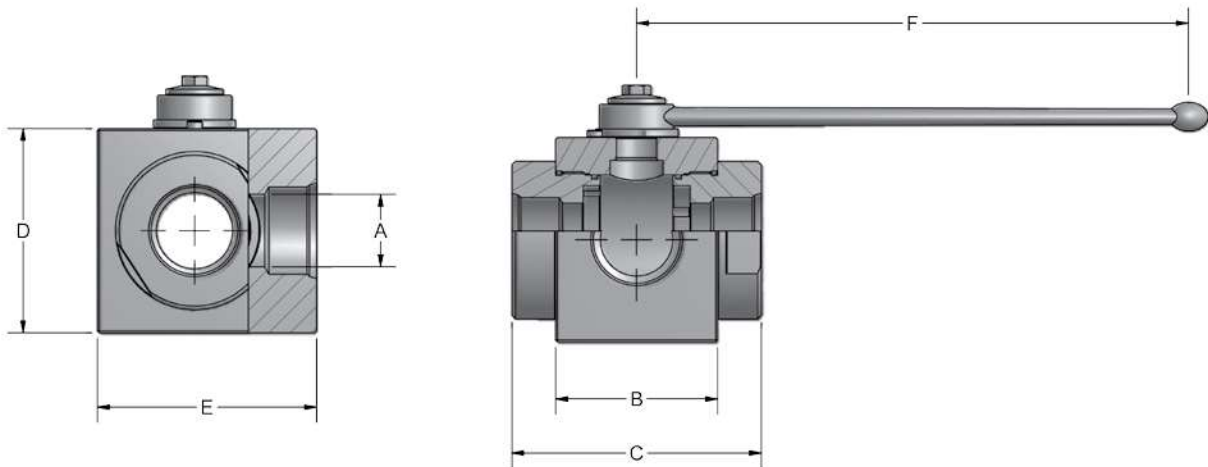

Standard handle supplied is C81302B. Refer to page 43 for details.

AB3 SERIES FULL BORE								
NPT	PSI MAX	A BORE	B	C	D	E	F	WEIGHT
AB3 L N1-1/4	5075	1.26	2.95	4.53	3.66	3.90	11.81	12.6 LBS
AB3 L N1-1/2	5075	1.57	3.35	5.16	4.21	4.53	11.81	19.0 LBS
AB3 L N2	5075	1.97	3.86	5.51	4.49	5.04	11.81	23.4 LBS

Only pressurize center port. Side ports should not be pressurized or be exposed to back-pressure that is greater than the inlet pressure. Failure to follow these guidelines will result in internal leakage through the valve.

NPT threads in accordance with ANSI B.1.20.1 specifications.





# AB3 Series - Three-Way Threaded

## Model Code Breakdown

AB3L N1 1/2 - 1 1 D B \_

**VALVE SERIES**

**PORT TYPE**

L	"Diverter" L-Port
---	-------------------

**CONNECTION TYPE/SIZE**

N	NPT Pipe Thread
---	-----------------

**BODY & ADAPTER MATERIAL**

1	Carbon Steel
---	--------------

**BALL & STEM MATERIAL**

1	Carbon Steel
---	--------------

**LOCKING KIT OR  
OPTIONAL HANDLE CODE**  
(See pages 42 & 43)

**ADAPTER & STEM SEALS**

B	Buna- Standard
V	Viton

**BALL & STEM SEATS**

D	POM- Standard
P	PEEK

Please consult your system's seal manufacturer for recommendation of seal selection, as Anchor Fluid Power does not accept responsibility for seal selection.

**MAXIMUM & MINIMUM WORKING TEMPERATURES FOR SEAL MATERIALS**

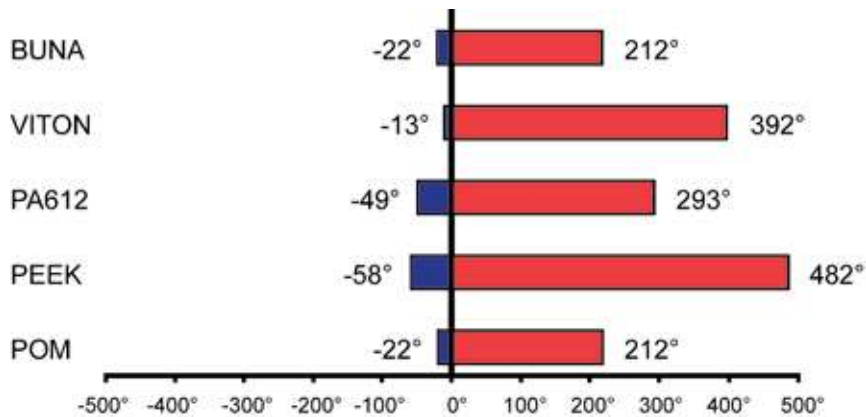

All temperatures are in degrees Fahrenheit.



# AES Series - Two-Way Block Body Flange Head



- Carbon Steel with Zinc Chromate Plating (RoHS Compliant)
- 316 stainless steel available from stock
- POM seats & Buna O-rings standard on carbon steel valves
- Optional seal materials available for extreme temperature applications & fluid compatibility (Consult Factory)

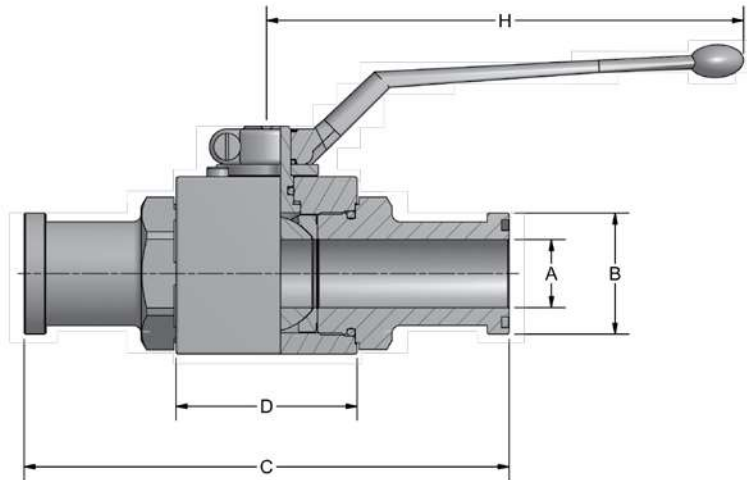
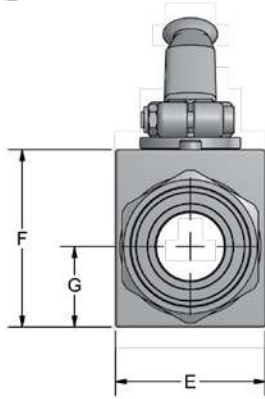

Standard handles supplied are:  
Refer to page 43 for details.

#8                    C1010ZB  
#12 & #16        C1200ZB

AES SERIES - CODE 61										
SERIES	PSI MAX	A BORE	B	C	D	E	F	G	H	WEIGHT
AES3#8	5000	.51	1.19	5.96	1.91	1.46	1.70	.71	4.33	2.1 LBS
AES3#12	5000	.79	1.50	6.38	2.46	1.77	2.17	.92	7.09	3.8 LBS
AES3#16	5000	.98	1.75	7.00	2.62	2.17	2.56	1.16	7.09	5.7 LBS

AES SERIES - CODE 62										
SERIES	PSI MAX	A BORE	B	C	D	E	F	G	H	WEIGHT
AES6#8	6000	.51	1.24	5.96	1.91	1.46	1.70	.71	4.33	2.1 LBS
AES6#12	6000	.79	1.63	6.85	2.46	1.77	2.17	.92	7.09	4.0 LBS
AES6#16	5000	.98	1.88	7.80	2.62	2.17	2.56	1.16	7.09	6.1 LBS



# AES Series - Two-Way Block Body Flange Head

## Model Code Breakdown

**AES3 #16 - 1 1 D B \_**

**VALVE SERIES**

AES3	Code 61
AES6	Code 62

**CONNECTION SIZE**

**BODY & ADAPTER MATERIAL**

1	Carbon Steel
2	316 Stainless Steel

**BALL & STEM MATERIAL**

1	Carbon Steel
2	316 Stainless Steel

**LOCKING KIT OR  
OPTIONAL HANDLE CODE**  
(See pages 42 & 43)

**ADAPTER & STEM SEALS**

B	Buna- Standard
V	Viton (Std on S/S)

**BALL & STEM SEATS**

D	POM- Standard
P	PEEK

Please consult your system's seal manufacturer for recommendation of seal selection, as Anchor Fluid Power does not accept responsibility for seal selection.

### MAXIMUM & MINIMUM WORKING TEMPERATURES FOR SEAL MATERIALS

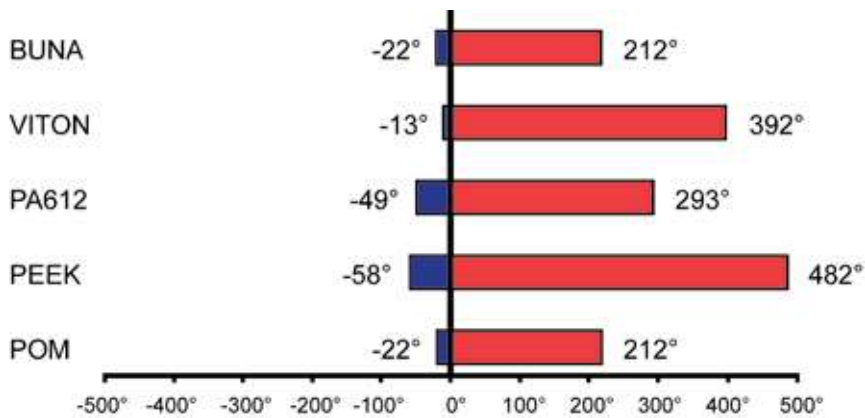

All temperatures are in degrees Fahrenheit.

# ABS Series - Two-Way Round Body Flange Head



- Carbon Steel with Zinc Chromate Plating (RoHS Compliant)
- 316 stainless steel available from stock
- POM seats & Buna O-rings standard on carbon steel valves
- Optional seal materials available for extreme temperature applications & fluid compatibility (Consult Factory)

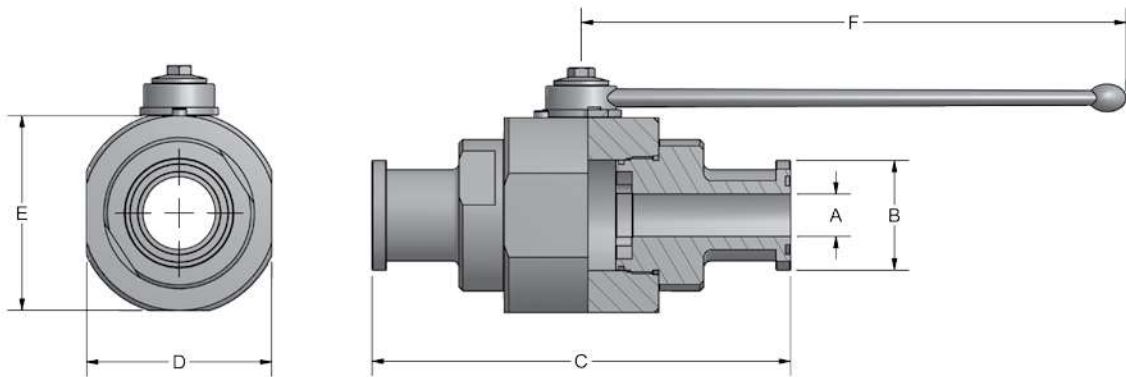

Standard handle supplied is C92501Z-SW17. Refer to page 43 for details.

ABS SERIES - CODE 61								
SERIES	PSI MAX	A BORE	B	C	D	E	F	WEIGHT
ABS3#20	4000	1.26	2.00	7.50	3.46	3.66	11.81	12.0 LBS
ABS3#24	3000	1.57	2.37	9.08	4.02	4.21	11.81	18.2 LBS
ABS3#32	3000	1.89	2.81	9.13	4.65	4.49	11.81	21.7 LBS

ABS SERIES - CODE 62								
SERIES	PSI MAX	A BORE	B	C	D	E	F	WEIGHT
ABS6#20	5000	1.26	2.13	8.78	3.46	3.66	11.81	12.8 LBS
ABS6#24	5000	1.57	2.50	11.06	4.02	4.21	11.81	18.2 LBS
ABS6#32	5000	1.89	3.13	12.44	4.65	4.49	11.81	26.0 LBS



# ABS Series - Two-Way Round Body Flange Head

## Model Code Breakdown

ABS3 #32 - 1 1 D B \_

**VALVE SERIES**

ABS3	Code 61
ABS6	Code 62

**CONNECTION SIZE**

**BODY & ADAPTER MATERIAL**

1	Carbon Steel
2	316 Stainless Steel

**BALL & STEM MATERIAL**

1	Carbon Steel
2	316 Stainless Steel

**LOCKING KIT OR  
OPTIONAL HANDLE CODE**  
(See pages 42 & 43)

**ADAPTER & STEM SEALS**

B	Buna- Standard
V	Viton (Std on S/S)

**BALL & STEM SEATS**

D	POM- Standard
P	PEEK

Please consult your system's seal manufacturer for recommendation of seal selection, as Anchor Fluid Power does not accept responsibility for seal selection.

### MAXIMUM & MINIMUM WORKING TEMPERATURES FOR SEAL MATERIALS

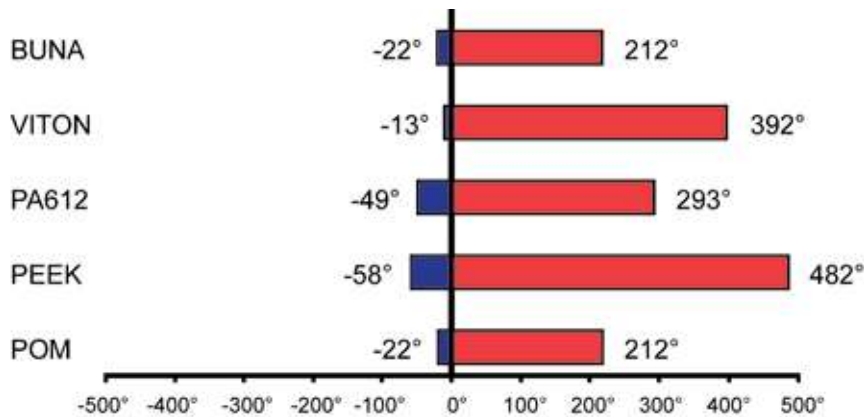

All temperatures are in degrees Fahrenheit.

# AEF Series - Two-Way Block Body Flat Face



- Carbon Steel with Zinc Chromate Plating (RoHS Compliant)
- 316 stainless steel available from stock
- POM seats & Buna O-rings standard on carbon steel valves
- Optional seal materials available for extreme temperature applications & fluid compatibility (Consult Factory)

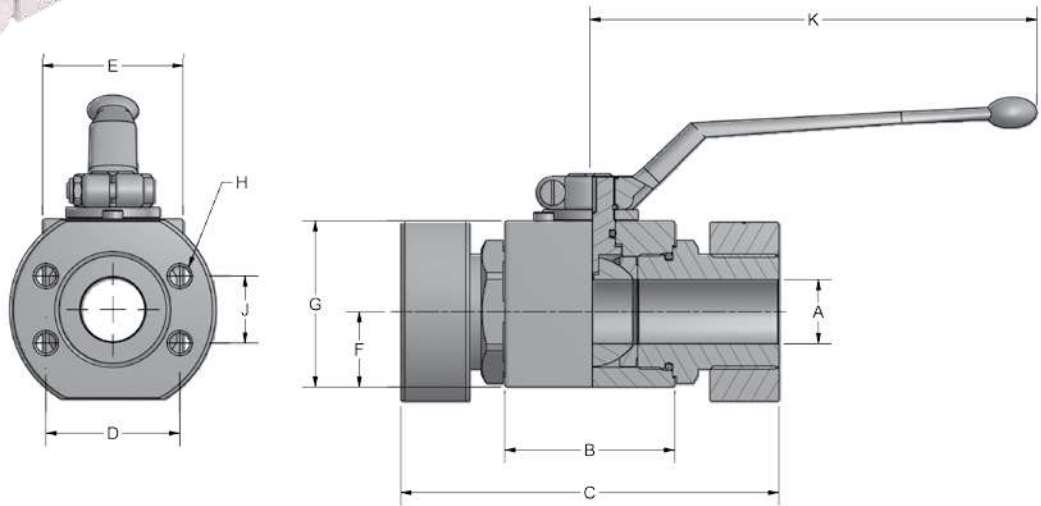

Standard handles supplied are:  
Refer to page 43 for details.

- |           |         |
|-----------|---------|
| #8        | C1010ZB |
| #12 - #16 | C1200ZB |

AEF SERIES - CODE 61												
SERIES	PSI MAX	A BORE	B	C	D	E	F	G	H UNC-2B	J	K	WEIGHT
AEF3#8	5000	.51	1.91	4.72	1.50	1.46	.71	1.69	5/16-18	.69	4.33	3.3 LBS
AEF3#12	5000	.79	2.46	5.35	1.87	1.77	.92	2.17	3/8-16	.87	7.09	5.7 LBS
AEF3#16	5000	.98	2.62	5.83	2.06	2.17	1.16	2.56	3/8-16	1.03	7.09	8.6 LBS

AEF SERIES - CODE 62												
SERIES	PSI MAX	A BORE	B	C	D	E	F	G	H UNC-2B	J	K	WEIGHT
AEF6#8	6000	.51	1.91	4.72	1.59	1.46	.71	1.69	5/16-18	.72	4.33	3.3 LBS
AEF6#12	6000	.79	2.46	5.35	2.00	1.77	.92	2.17	3/8-16	.94	7.09	5.7 LBS
AEF6#16	5000	.98	2.62	5.83	2.25	2.17	1.16	2.56	7/16-14	1.09	7.09	8.6 LBS



# AEF Series - Two-Way Block Body Flat Face

## Model Code Breakdown

AEF3 #16 - 1 1 D B \_

**VALVE SERIES**

AEF3	Code 61
AEF6	Code 62

**CONNECTION SIZE**

**BODY & ADAPTER MATERIAL**

1	Carbon Steel
2	316 Stainless Steel

**BALL & STEM MATERIAL**

1	Carbon Steel
2	316 Stainless Steel

**LOCKING KIT OR  
OPTIONAL HANDLE CODE**  
(See pages 42 & 43)

**ADAPTER & STEM SEALS**

B	Buna- Standard
V	Viton (Std on S/S)

**BALL & STEM SEATS**

D	POM- Standard
P	PEEK

Please consult your system's seal manufacturer for recommendation of seal selection, as Anchor Fluid Power does not accept responsibility for seal selection.

### MAXIMUM & MINIMUM WORKING TEMPERATURES FOR SEAL MATERIALS

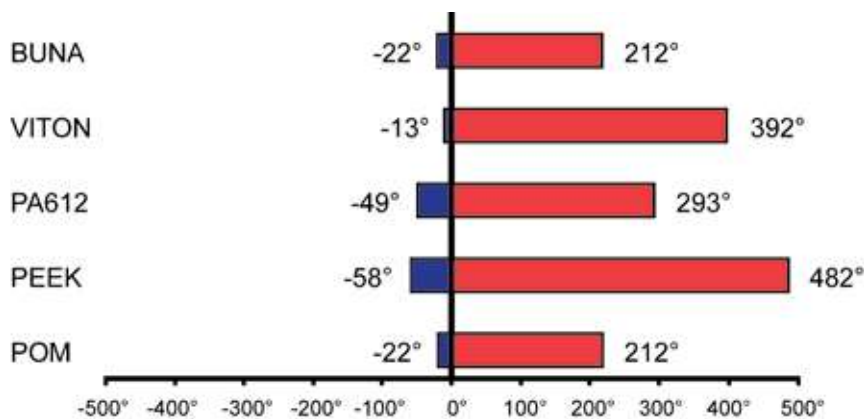

All temperatures are in degrees Fahrenheit.

# ABF Series - Two-Way Rounded Body Flat Face



- Carbon Steel with Zinc Chromate Plating (RoHS Compliant)
- 316 stainless steel available from stock
- POM seats & Buna O-rings standard on carbon steel valves
- Optional seal materials available for extreme temperature applications & fluid compatibility (Consult Factory)

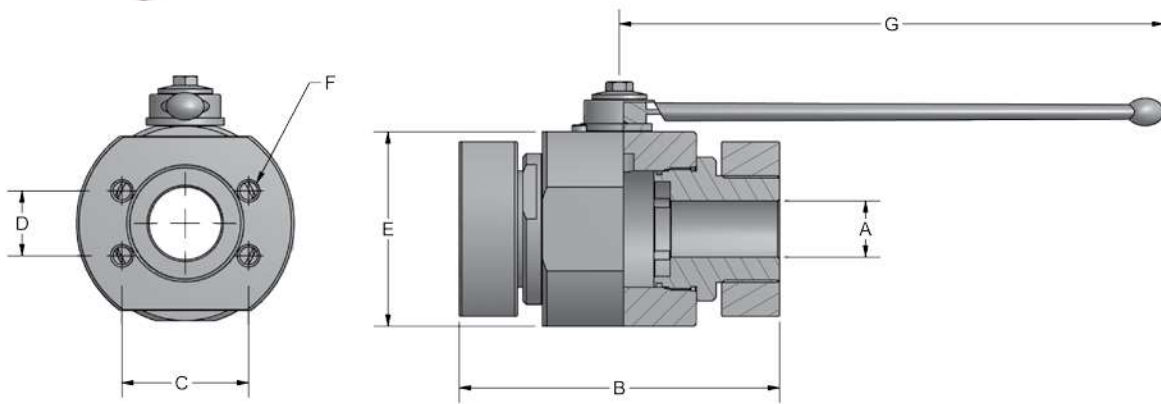

Standard handle supplied is C92501Z-SW17. Refer to page 43 for details.

ABF SERIES - CODE 61									
SERIES	PSI MAX	A BORE	B	C	D	E	F UNC-2B	G	WEIGHT
ABF3#20	4000	1.26	6.77	2.31	1.19	3.66	7/16-14	11.81	17.9 LBS
ABF3#24	3000	1.57	6.95	2.75	1.41	4.21	1/2-13	11.81	24.6 LBS
ABF3#32	3000	1.89	7.72	3.06	1.69	4.49	1/2-13	11.81	33.8 LBS

ABF SERIES - CODE 62									
SERIES	PSI MAX	A BORE	B	C	D	E	F UNC-2B	G	WEIGHT
ABF6#20	5000	1.26	6.77	2.63	1.25	3.66	1/2-13	11.81	17.9 LBS
ABF6#24	5000	1.57	6.95	3.13	1.44	4.21	5/8-11	11.81	24.6 LBS
ABF6#32	5000	1.89	7.72	3.81	1.75	4.49	3/4-10	11.81	33.8 LBS



# ABF Series - Two-Way Rounded Body Flat Face

## Model Code Breakdown

ABF3 #32 - 1 1 D B \_

**VALVE SERIES**

ABF3	Code 61
ABF6	Code 62

**CONNECTION SIZE**

**BODY & ADAPTER MATERIAL**

1	Carbon Steel
2	316 Stainless Steel

**BALL & STEM MATERIAL**

1	Carbon Steel
2	316 Stainless Steel

**LOCKING KIT OR  
OPTIONAL HANDLE CODE**  
(See pages 42 & 43)

**ADAPTER & STEM SEALS**

B	Buna- Standard
V	Viton (Std on S/S)

**BALL & STEM SEATS**

D	POM- Standard
P	PEEK

Please consult your system's seal manufacturer for recommendation of seal selection, as Anchor Fluid Power does not accept responsibility for seal selection.

**MAXIMUM & MINIMUM WORKING TEMPERATURES FOR SEAL MATERIALS**

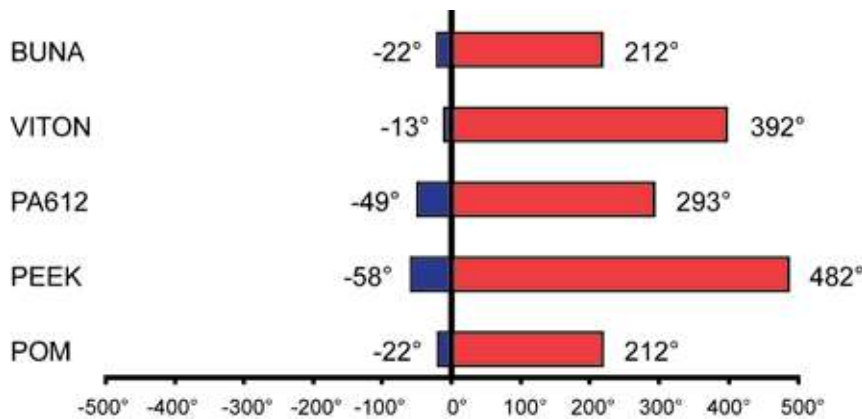

All temperatures are in degrees Fahrenheit.



# AES/F & ABS/F Series

## Flange Head X Flat-Face

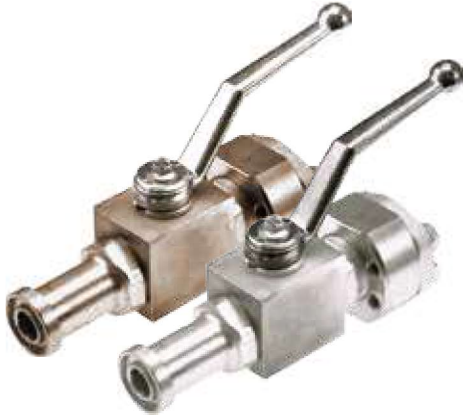

- Flange Head X Flat-Face connections for insertion in between existing flange joints
- Ideal for flange mounting anywhere a flange connection exists or where hoses are already connected
- Carbon Steel with Zinc Chromate Plating (RoHS Compliant)
- 316 stainless steel available
- POM seats & Buna O-rings standard on carbon steel valves
- Optional seal materials available for extreme temperature applications & fluid compatibility (Consult Factory)

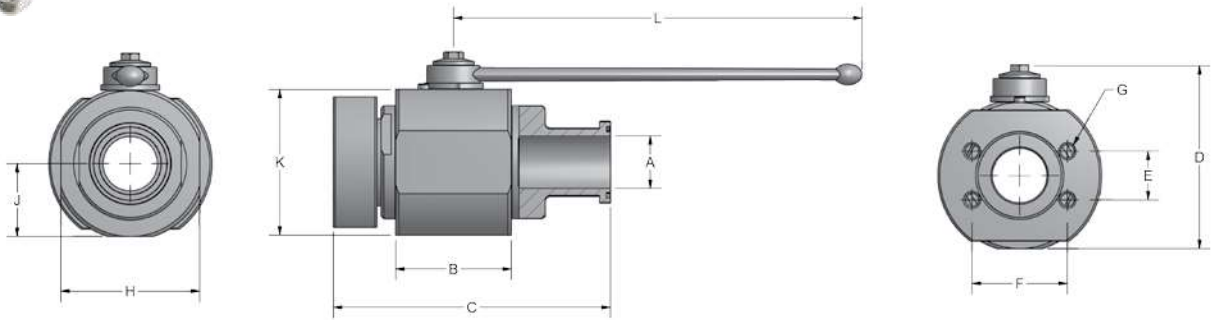

Standard handles supplied are: #8 C1010ZB  
 #12 - #16 C1200ZB  
 Refer to page 43 for details. #20 - #32 C92501Z-SW17

AES/F SERIES												
SERIES	PSI MAX	A BORE	B	C	D	E	F	G UNC-2B	H	J	K	L
AES/F3#8	5000	.51	1.91	5.3	2.24	.69	1.50	5/16-18	1.46	.71	1.69	4.33
AES/F6#8	6000	.51	1.91	5.3	2.24	.72	1.59	5/16-18	1.46	.71	1.69	4.33
AES/F3#12	5000	.79	2.46	5.8	2.89	.87	1.87	3/8-16	1.77	.92	2.17	7.09
AES/F6#12	6000	.79	2.46	6.1	2.89	.94	2.00	3/8-16	1.77	.92	2.17	7.09
AES/F3#16	5000	.98	2.62	6.4	3.29	1.03	2.06	3/8-16	2.17	1.16	2.56	7.09
AES/F6#16	5000	.98	2.62	6.8	3.29	1.09	2.25	7/16-14	2.17	1.16	2.56	7.09

ABS/F SERIES												
SERIES	PSI MAX	A BORE	B	C	D	E	F	G UNC-2B	H	J	K	L
ABS/F3#20	4000	1.26	2.96	7.2	4.39	1.19	2.31	7/16-14	2.36	1.83	3.66	11.81
ABS/F6#20	5000	1.26	2.96	7.8	4.39	1.25	2.63	1/2-13	2.36	1.83	3.66	11.81
ABS/F3#24	3000	1.57	3.36	8.0	4.94	1.41	2.75	1/2-13	2.95	2.11	4.21	11.81
ABS/F6#24	5000	1.57	3.36	9.0	4.94	1.44	3.13	5/8-11	2.95	2.11	4.21	11.81
ABS/F3#32	3000	1.97	3.86	8.4	5.22	1.69	3.06	1/2-13	3.35	2.24	4.49	11.81
ABS/F6#32	5000	1.97	3.86	9.5	5.22	1.75	3.81	3/4-10	3.35	2.24	4.49	11.81



# AES/F & ABS/F Series

## Flange Head X Flat-Face

### Model Code Breakdown

AES/F3 #8 - 1 1 D B \_

**VALVE SERIES**

AES/F3	Code 61 Block Body
AES/F6	Code 62 Block Body
ABS/F3	Code 61 Round Body
ABS/F6	Code 62 Round Body

**CONNECTION SIZE**

**BODY & ADAPTER MATERIAL**

1	Carbon Steel
2	316 Stainless Steel

**BALL & STEM MATERIAL**

1	Carbon Steel
2	316 Stainless Steel

**LOCKING KIT OR  
OPTIONAL HANDLE CODE**  
(See pages 42 & 43)

**ADAPTER & STEM SEALS**

B	Buna- Standard
V	Viton (Std on S/S)

**BALL & STEM SEATS**

D	POM- Standard
P	PEEK

Please consult your system's seal manufacturer for recommendation of seal selection, as Anchor Fluid Power does not accept responsibility for seal selection.

**MAXIMUM & MINIMUM WORKING TEMPERATURES FOR SEAL MATERIALS**

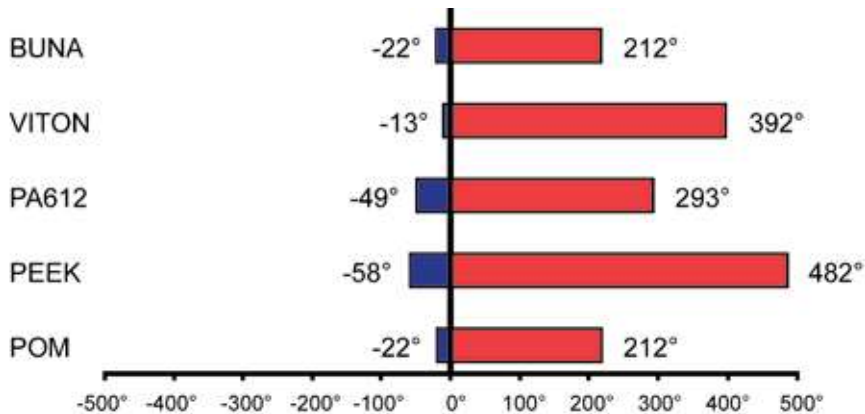

All temperatures are in degrees Fahrenheit.

# APK Series - Two-Way Manifold Mount



- Carbon Steel with Zinc Chromate Plating (RoHS Compliant)
- POM seats & Buna O-rings standard on carbon steel valves
- Optional seal materials available for extreme temperature applications & fluid compatibility (Consult Factory)

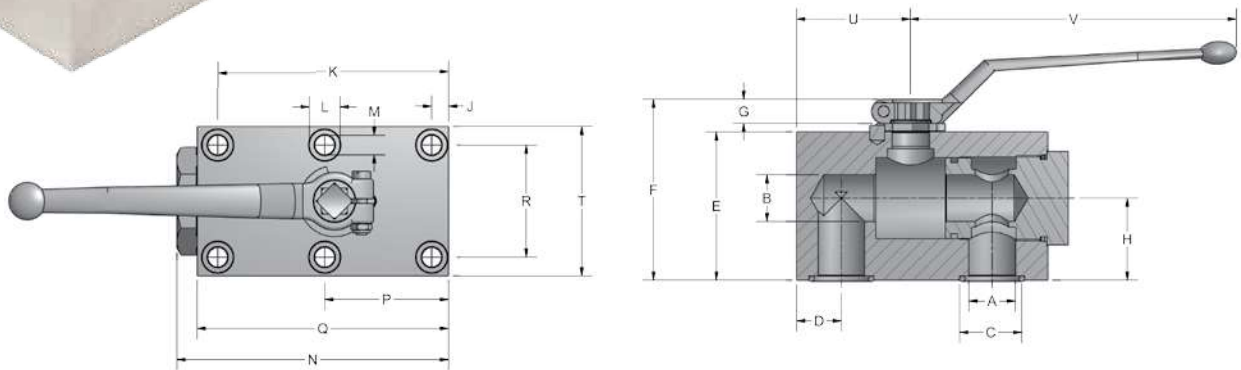

Standard handles supplied are: #4 - #8 C1010ZB  
 Refer to page 43 for details. #12 - #16 C1200ZB  
 #20 - #24 C92501Z

APK SERIES									
SERIES	PSI MAX	A	B	C	D	E	F	G	H
APK2 #4	7250	.24	.24	.464	.37	1.38	1.67	.30	.89
APK2 #6	7250	.39	.39	.586	.39	1.77	2.32	.43	.89
APK2 #8	5800	.51	.51	.980	.71	2.17	2.72	.43	1.18
APK2 #12	5075	.79	.79	1.141	.83	2.76	3.48	.55	1.52
APK2 #16	5075	.98	.98	1.374	.94	3.13	3.86	.55	1.73
APK2 #20	5075	1.26	1.26	1.562	1.10	4.15	4.88	.55	2.31
APK2 #24	5075	1.46	1.57	1.877	1.14	4.53	5.26	.55	2.41

APK SERIES (CONT'D)											
SERIES	J	K	L	M	N	P	Q	R	T	U	V
APK2 #4	.354	1.73	.413	.255	2.54	*N/A	2.28	1.062	1.57	1.04	4.33
APK2 #6	.295	2.46	.531	.334	3.13	*N/A	2.76	1.574	2.17	1.13	4.33
APK2 #8	.374	3.64	.531	.334	4.35	2.00	3.94	1.771	2.36	1.73	4.33
APK2 #12	.452	4.27	.649	.413	5.08	2.36	4.65	2.007	2.76	2.05	7.09
APK2 #16	.354	4.88	.649	.413	5.74	2.62	5.31	2.362	3.15	2.41	7.09
APK2 #20	.433	5.79	.748	.511	7.22	3.11	6.50	3.070	3.94	2.91	11.81
APK2 #24	1.141	5.55	.984	.649	7.93	3.35	7.28	3.740	5.12	3.35	11.81

\*Valve sizes #4 & #6 only have (4) mounting holes.



# APK Series - Two-Way Manifold Mount

## Model Code Breakdown

APK2 #20 - 1 1 D B

**VALVE SERIES**

APK2	Manifold Mount 2-way
------	----------------------

**CONNECTION SIZE**

20	
----	--

**BODY & ADAPTER MATERIAL**

1	Carbon Steel
---	--------------

**BALL & STEM MATERIAL**

1	Carbon Steel
---	--------------

**ADAPTER & STEM SEALS**

B	Buna- Standard
V	Viton

**BALL & STEM SEATS**

D	POM- Standard
P	PEEK

Please consult your system's seal manufacturer for recommendation of seal selection, as Anchor Fluid Power does not accept responsibility for seal selection.

**MAXIMUM & MINIMUM WORKING TEMPERATURES FOR SEAL MATERIALS**

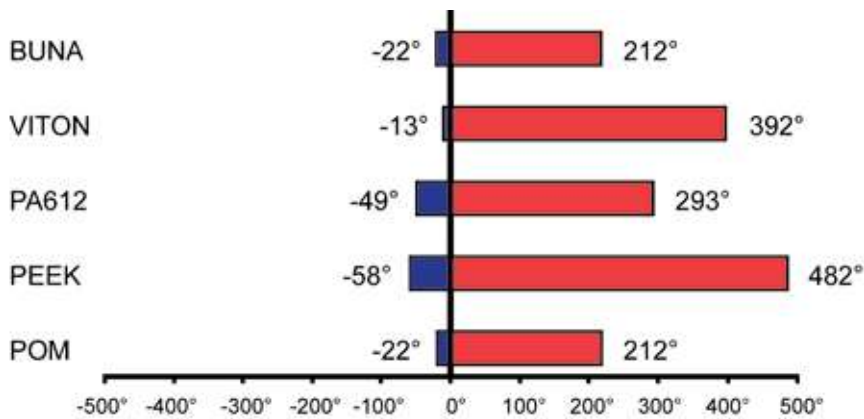

All temperatures are in degrees Fahrenheit.

## Locking Kits

LOCKING KITS AVAILABLE FROM STOCK			
PART NUMBER	VALVE SIZE	MATERIAL	SUFFIX*
LK6	1/8" - 1/2"	CARBON STEEL	L
LK20	3/4" - 1"	CARBON STEEL	L
LK32	1 1/4" - 2"	CARBON STEEL	L
LK6-S/S	1/8" - 1/2"	STAINLESS STEEL	L
LK20-S/S	3/4" - 1"	STAINLESS STEEL	L
LK32-S/S	1 1/4" - 2"	STAINLESS STEEL	L

\*Add this suffix to the end of the valve part # to receive the corresponding locking kit for that size valve- installed at the factory. Carbon steel valves receive carbon steel locking kits. Stainless steel valves receive stainless locking kits.

### "L" Style Lock

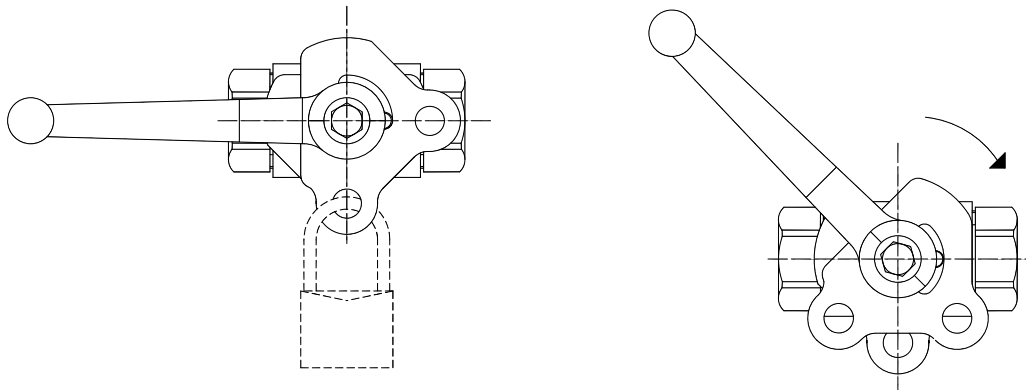

Consult factory for details concerning tamper proof fastener options.



# Handles

**HANDLES FOR 1/8" THROUGH 1/2" VALVES**



C0020ZB  
Zinc Alloy  
Fits 1/8" - 1/2" Valves  
5 - 7/8" Long  
Code "A"



C1010ZB  
Zinc Alloy  
Fits 1/8" - 1/2" Valves  
4 - 1/4" Long



C10106H  
Stainless Steel  
Fits 1/8" - 1/2" Valves  
4 - 1/4" Long  
Code "C"

**HANDLES FOR 3/4" THROUGH 1" VALVES**



C1200ZB  
Zinc Alloy  
Fits 3/4" - 1" Valves  
7" Long  
Code "Z"



C69206H  
Stainless Steel  
Fits 3/4" - 1" Valves  
7 - 7/8" Long  
Code "W"



C2950AV  
Aluminum  
Fits 3/4" - 1" Valves  
8" Long  
Code "Y"

**HANDLES FOR 1 1/4" THROUGH 2" VALVES**



C81306H-SW17  
Stainless Steel  
Fits 1 1/4" - 2" Valves  
11 - 3/4" Long  
Code "F"



C81302B-SW17  
Carbon Steel  
Fits 1 1/4" - 2" Valves  
11 - 3/4" Long  
Code "E"



C92506H-SW17  
Stainless Steel  
Fits 1 1/4" - 2" Valves  
12 - 1/8" Long  
Code "J"



C92501Z-SW17  
Carbon Steel  
Fits 1 1/4" - 2" Valves  
12 - 1/8" Long  
Code "H"

Dimensions are approximate and are subject to change without notice. For exact dimensional info, please consult the factory with the specific handle part #.

# HYDRAULIC BALL VALVES

## LV2B Series - 1000 WOG Stainless Steel



- All stainless steel construction
- Locking handles standard
- Ideal for suction, pressure and return lines
- Available in NPT & SAE threads
- Mounting holes standard on SAE #16 - #64

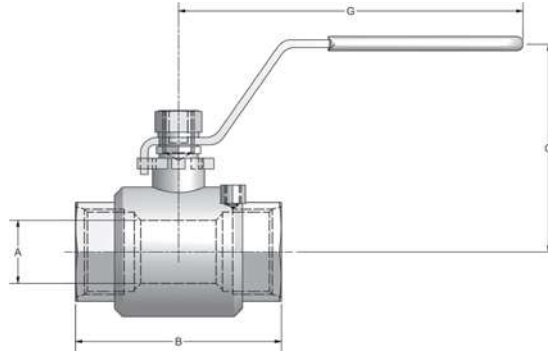
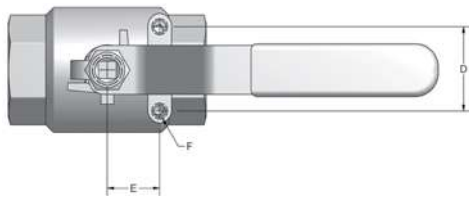

LV2B SERIES - NPT							
SIZE	A	B	C	D	E	F UNC	G
1/4"	.36	2.13	2.13	1.12	.49	N/A	4.33
3/8"	.50	2.13	2.17	1.12	.49	N/A	4.33
1/2"	.59	2.24	2.28	1.12	.49	N/A	4.53
3/4"	.79	2.68	2.40	1.12	.49	N/A	4.53
1"	.98	3.15	3.03	1.38	.91	N/A	5.04
1-1/4"	1.26	3.58	3.19	1.48	1.00	N/A	5.04
1-1/2"	1.50	4.06	3.54	1.48	1.00	N/A	6.10
2"	1.97	4.88	4.25	1.50	1.00	N/A	6.10
2-1/2"	2.56	6.30	5.20	N/A	N/A	N/A	9.06
3"	3.15	7.28	5.71	N/A	N/A	N/A	9.06

LV2B SERIES - SAE							
SIZE	A	B	C	D	E	F UNC	G
1/4"	.35	2.40	2.13	1.12	.49	N/A	4.33
3/8"	.47	2.40	2.17	1.12	.49	N/A	4.33
1/2"	.59	2.52	2.28	1.12	.49	N/A	4.53
3/4"	.79	3.23	2.40	1.12	.49	N/A	4.53
1"	.98	3.62	3.03	1.38	.91	1/4-20	5.04
1-1/4"	1.26	3.96	3.19	1.48	1.00	1/4-20	5.04
1-1/2"	1.50	4.23	3.54	1.48	1.00	1/4-20	6.10
2"	1.97	4.90	4.25	1.50	1.00	1/4-20	6.10
2 1/2"	2.56	6.30	5.20	2.25	1.18	1/4-20	9.06
3"	3.15	7.28	5.71	2.76	1.18	1/4-20	9.06
*4"	3.93	8.80	7.11	2.76	1.18	1/4-20	13.00

MODEL CODE:

LV2B N 1/2" -2T

THREAD TYPE (N-NPT; S-SAE)

THREAD SIZE (EX. N1/2"; S#8)

COMPONENT MATERIALS		
COMPONENT	MATERIAL	QTY
VALVE BODY	ASTM A351 GR CF8M	1
TAILPIECE	ASTM A351 GR CF8M	1
BALL	ASTM A351 GR CF8M	1
STEM	316	1
BALL SEAT	PTFE	2
STEM SEAT	PTFE	1
STEM PACKING	PTFE	1
STEM GLAND	304	1
HANDLE	304	1
STEM LOCK WASHER	304	1
STEM NUT	304	1
HANDLE SLEEVE	VINYL	1
LOCK	304	1

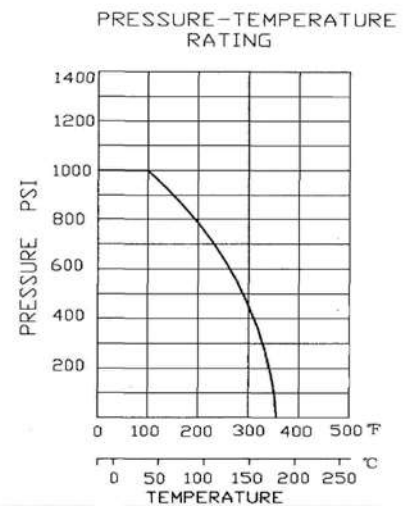

\* 4"SAE - 500 PSI max for LV2BS#64-2T-MH

\*\* For WOG Accessories refer to pages 67



866-FLANGES | 513.527.4444 | Fax 513.527.4449

sales@anchorfluidpower.com | anchorfluidpower.com

**MV2B Series - 2000 WOG Stainless Steel**



- All stainless steel construction
- Locking handles standard
- Ideal for suction, pressure and return lines
- Available in NPT & SAE threads

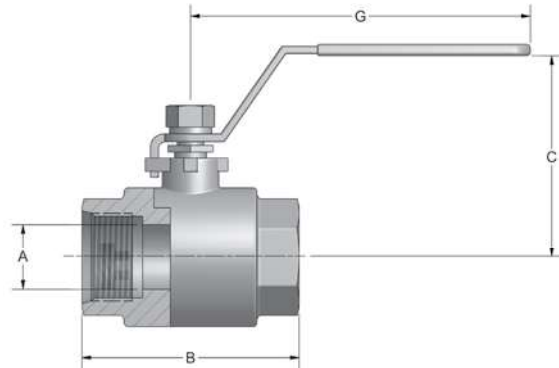
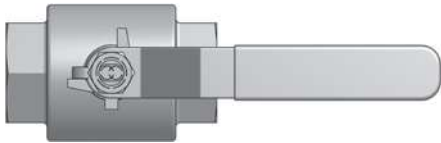

MV2B SERIES - NPT				
SIZE	A	B	C	G
1/4"	.36	2.13	2.13	4.33
3/8"	.50	2.13	2.17	4.33
1/2"	.59	2.24	2.28	4.53
3/4"	.79	2.76	2.40	4.53
1"	.98	3.25	3.03	5.04
1-1/4"	1.26	3.58	3.19	5.04
1-1/2"	1.50	4.06	3.54	6.10
2"	1.97	4.90	4.25	6.10

MV2B SERIES - SAE				
SIZE	A	B	C	G
1/4"	.35	2.40	2.13	4.33
3/8"	.47	2.40	2.17	4.33
1/2"	.59	2.52	2.28	4.53
3/4"	.79	3.23	2.40	4.53
1"	.98	3.62	3.03	5.04
1-1/4"	1.26	3.96	3.19	5.04
1-1/2"	1.50	4.23	3.54	6.10
2"	1.97	4.90	4.25	6.10

**MODEL CODE:**

**MV2B N 1/2" -2T**

**THREAD TYPE (N-NPT; S-SAE)**

**THREAD SIZE (EX. N1/2"; S#8)**

COMPONENT MATERIALS		
COMPONENT	MATERIAL	QTY
VALVE BODY	ASTM A351 GR CF8M	1
TAILPIECE	ASTM A351 GR CF8M	1
BALL	ASTM A351 GR CF8M	1
STEM	316	1
BALL SEAT	PTFE	2
STEM SEAT	PTFE	1
STEM PACKING	PTFE	1
STEM GLAND	304	1
HANDLE	304	1
STEM LOCK WASHER	304	1
STEM NUT	304	1
HANDLE SLEEVE	VINYL	1
LOCK	304	1

PRESSURE-TEMPERATURE RATING

