

7 TONS-INVERTED TELESCOPIC CYLINDERS (2100 PSI MAX. WORKING PRESSURE)															
PART NUMBER	CAPACITY	STROKE	OUTSIDE DIAMETER	A	B	C	D	E	F	G	H	I	J	PORT	WEIGHT (LBS)
TC-07833-S-PT	7 TONS	78"	3.75"	34.62"	7.00"	0.87"	2.00"	1.015"	1.25"	2.25"	1.25"	9.00"	4.25"	1/2 SAE-08	86
TC-09033-S-PT		90"	3.75"	38.62"											94
TC-10833-S-PT		108"	3.75"	44.62"											106

12 TONS-INVERTED TELESCOPIC CYLINDERS (2450 PSI MAX. WORKING PRESSURE)															
PART NUMBER	CAPACITY	STROKE	OUTSIDE DIAMETER	A	B	C	D	E	F	G	H	I	J	PORT	WEIGHT (LBS)
TC-07843-S-PT	12 TONS	78"	4.50"	33.87"	7.00"	0.87"	2.00"	1.015"	1.50"	2.25"	1.50"	10.50"	5.00"	1/2 SAE-0	99
TC-09043-S-PT		90"	4.50"	37.87"											109
TC-10843-S-PT		108"	4.50"	43.87"											125
TC-12043-S-PT		120"	4.50"	47.87"	13.00"	0.87"	2.00"	1.015"	1.50"	2.25"	1.50"	10.50"	5.00"		138
TC-12043M-S-PT		120"	4.50"	47.87"											137
TC-13243M-S-PT		132"	4.50"	51.87"											157
TC-14443M-S-PT		144"	4.50"	55.87"											171

RETRACTED TOLERANCE ± 1/8"

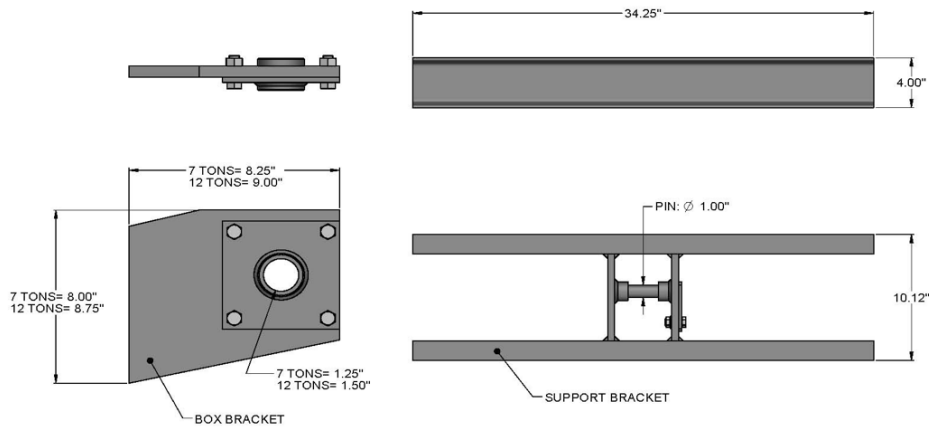

TELESCOPIC ACCESSORIES	
PART NUMBER	DESCRIPTION
TC-SB	BRACKET FOR 7 AND 12 TONS
TC-S07	BOX BRACKET KIT 7 TONS
TC-S12	BOX BRACKET KIT 12 TONS

HYDRO CUSTOM IS NOT RESPONSIBLE FOR INCORRECT RESULTS OBTAINED WITH FIGURES IN THIS DOCUMENT. INFORMATION IS FOR REFERENCE ONLY. NO OTHER CONDITIONS ARE EXPRESSED OR IMPLIED.