

# FLOW NEEDLE & CHECK VALVES



866-FLANGES | 513.527.4444 | Fax 513.527.4449  
sales@anchorfluidpower.com | anchorfluidpower.com

<b>Carbon Steel Check Valves</b>	<b>4</b>
<b>Carbon Steel Flow Control Valves</b>	<b>6</b>
<b>Carbon Steel Needle Valves</b>	<b>8</b>

# Check Valves - Carbon Steel



- NPTF & SAE Connections
- Carbon Steel with Zinc Chromate Plating (RoHS Compliant)
- Available in 7 PSI & 65 PSI Spring Cracking Pressures
- Metal to Metal Seat
- Hardened Poppet
- Temperature Range -4°F to +176°F

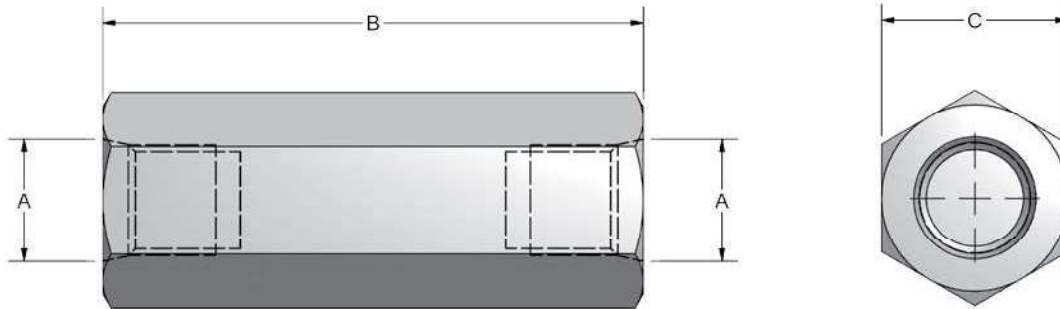
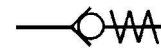

CHECK VALVES						
A		B	C	MAX PSI	MAX FLOW GPM	WEIGHT (LBS)
NPTF	SAE					
1/4"	#4	2.17	.75	5700	4	.2
3/8"	N/A	2.68	.95	5700	8	.4
N/A	#6	2.28	.75	5700	8	.2
1/2"	N/A	2.95	1.06	5700	13	.5
N/A	#8	2.72	.95	5700	13	.4
3/4"	#12	3.48	1.38	5700	23	1.0
1"	#16	4.33	1.61	5000	40	1.6
1 1/4"	#20	4.72	2.17	5000	50	3.4
1 1/2"	#24	5.43	2.56	5000	80	5.6
2"	#32	5.43	2.95	4500	110	6.7



# Check Valves - Carbon Steel

## Model Code Breakdown

C N 1/2 - 1 - 7

VALVE SERIES

THREAD TYPE

N	NPTF Pipe Thread
S#	SAE Straight Thread

THREAD SIZE

Example	N1/2
	S#8

CRACKING PRESSURE

7	7 PSI
65	65 PSI

MATERIAL

1	Carbon Steel
---	--------------

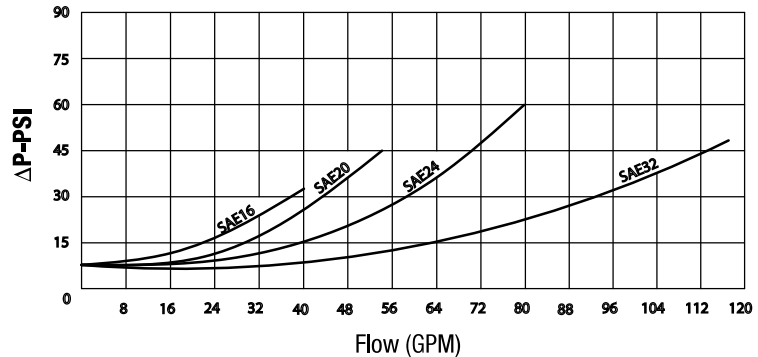
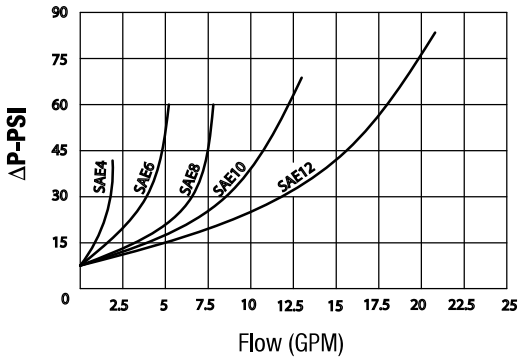
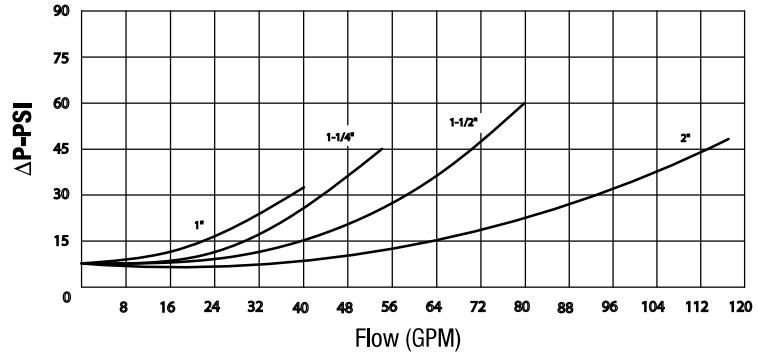
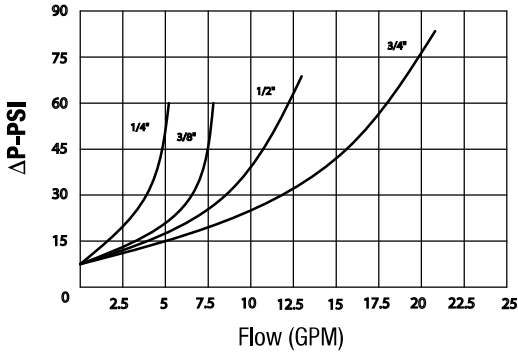

# Flow Control Valves - Carbon Steel



- NPTF & SAE Connections
- Carbon Steel with Zinc Chromate Plating (RoHS Compliant)
- Set Screw Allows Knob to be Locked into Position
- Graduated Knob & Spindle for Accurate Flow Control
- 7 PSI Standard Spring Setting
- Buna O-Ring / PTFE Stem Packing
- Temperature Range -4°F to +176°F
- These valves are for control of flow only. Not to be used as isolation or shut-off valves

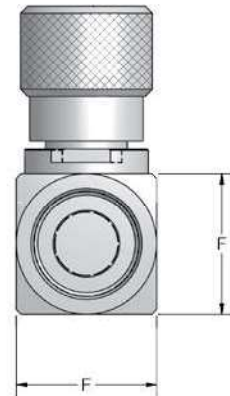
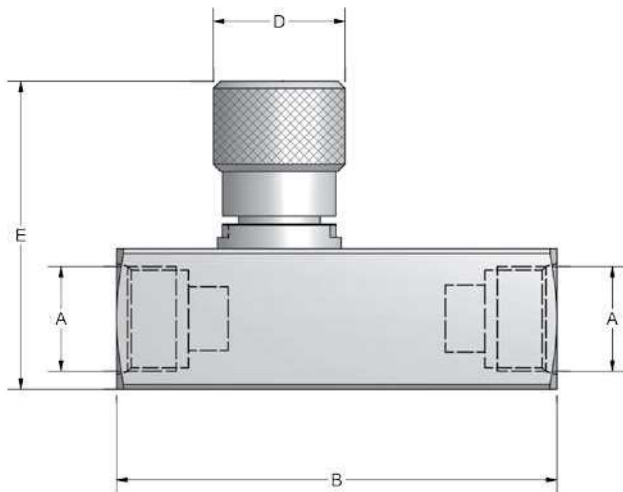
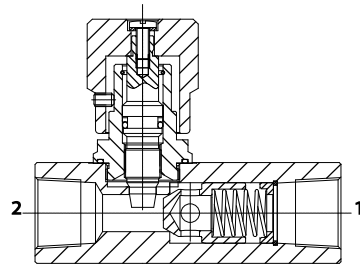
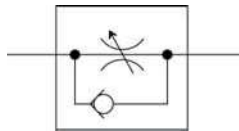

FLOW CONTROL VALVES								
A		B	D	E	F	MAX PSI	MAX FLOW GPM	WEIGHT (LB)
NPTF	SAE							
1/4	#4	2.60	1.18	2.67	0.98	5700	4	0.83
3/8	#6	3.00	1.18	2.67	0.98	5700	8	0.86
1/2	#8	3.58	1.29	2.79	1.18	5700	13	1.4
3/4	#12	4.43	1.65	3.70	1.57	5700	21	3.0
1	#16	5.55	1.65	3.93	1.77	5700	40	4.2
1-1/4	#20	6.10	2.08	4.78	2.16	4000	50	7.0
1-1/2	#24	6.61	2.08	5.17	2.55	4000	80	10.0





# Needle Valves - Carbon Steel



- NPTF & SAE Connections
- Carbon Steel with Zinc Chromate Plating (RoHS Compliant)
- Set Screw Allows Knob to be Locked into Position
- Graduated Knob & Spindle for Accurate Flow Control
- Buna O-Ring / PTFE Stem Packing
- Temperature Range -4°F to +176°F
- These valves are for control of flow only. Not to be used as isolation or shut-off valves

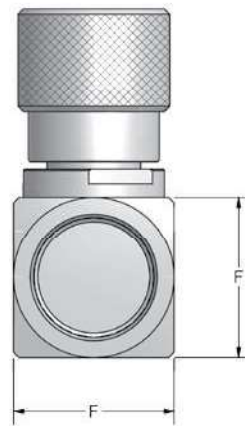
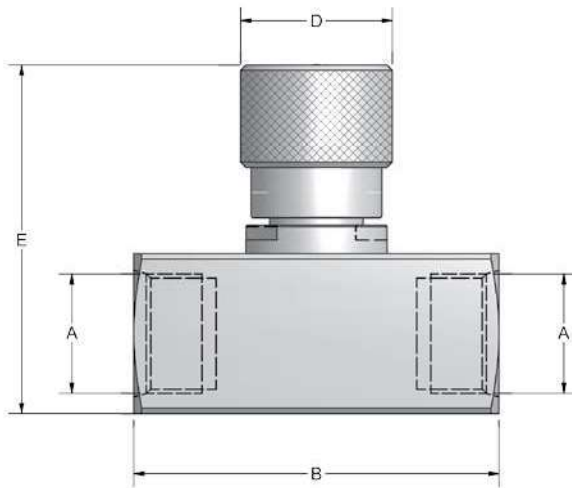
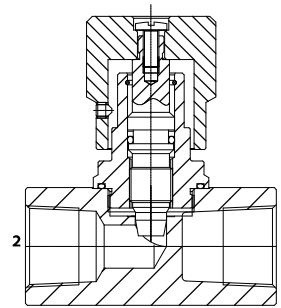
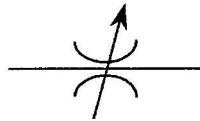

NEEDLE VALVES								
A		B	D	E	F	MAX PSI	MAX FLOW GPM	WEIGHT (LB)
NPTF	SAE							
1/4	#4	2.12	1.18	2.67	0.98	5700	4	0.70
3/8	#6	2.12	1.18	2.67	0.98	5700	8	0.66
1/2	#8	2.51	1.29	2.85	1.18	5700	13	1.0
3/4	#12	3.19	1.65	3.70	1.57	5700	21	2.3
1	#16	4.00	1.65	3.93	1.77	5700	40	3.2
1-1/4	#20	4.02	2.08	4.78	2.16	4000	50	5.0
1-1/2	#24	4.02	2.08	5.17	2.55	4000	80	6.5



# Needle Valves - Carbon Steel

## Model Code Breakdown

N N 1/2 - 1

Valve Series •

• Material

Thread Type •

1	Carbon Steel
---	--------------

N	NPTF Pipe Thread
S#	SAE Straight Thread

• Thread Size

Example	N1/2
	S#8

### NPTF

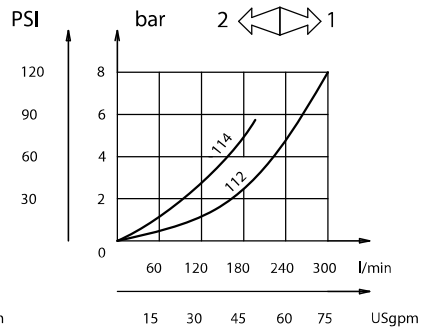
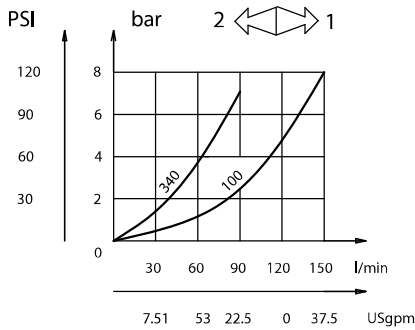
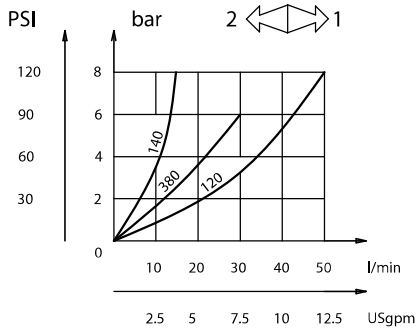

### SAE

