

NOTES:

PORT SIZE: A, B, P, T, SAE#10
VALVE MTG: UNC#1/4-20X 0.75 DP

MATERIAL: ALUMINIUM 6061-T6
YIELD RESISTANCE: 40000 PSI
ULTIMATE RESISTANCE: 45000 PSI

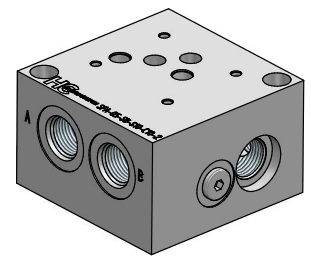
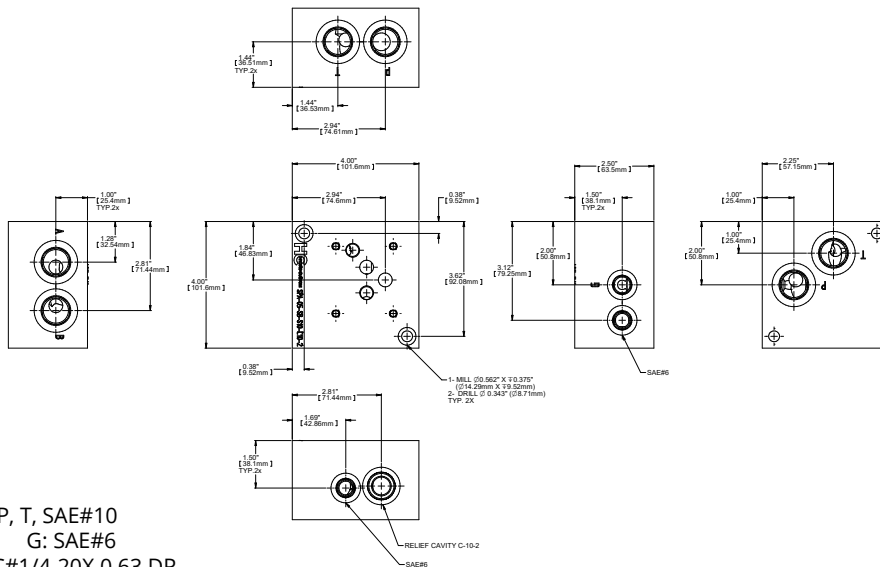

NOTES:

PORT SIZE: A, B, P, T, SAE#10
G: SAE#6
VALVE MTG: UNC#1/4-20X 0.63 DP

MATERIAL: ALUMINIUM 6061-T6
YIELD RESISTANCE: 40000 PSI
ULTIMATE RESISTANCE: 45000 PSI